

E0434P1

Type	Rated voltage(V)	Frequency(Hz)	Input current(A)	Input power(W)	Rated speed(r/min)	Max Air flow(m³/h)	Noise(dBA)	Perm.amb.temp(°C)
EC072/13E3G01-AS172/45P1-01	230VAC	50/60	0.18	21±10%	2500/1700	550±10%	≤63	-30~+50

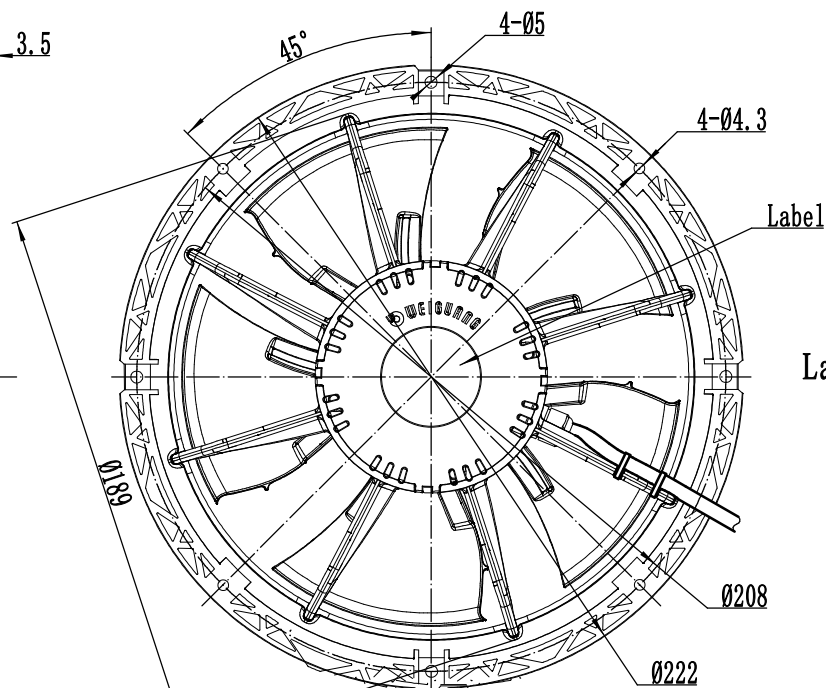

Label:

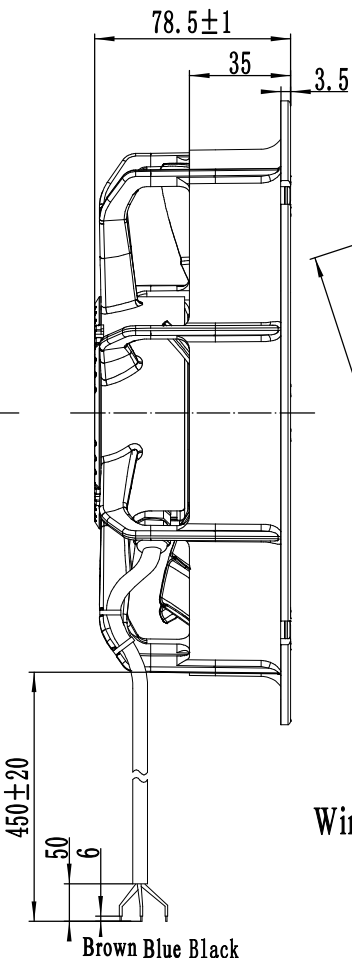
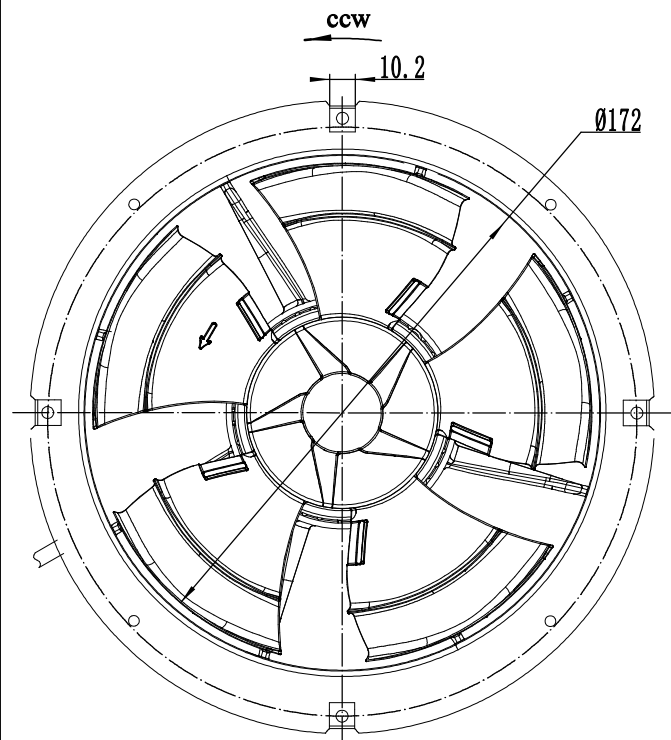

Performance curve:

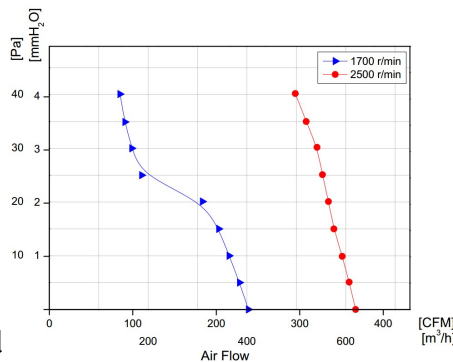

Wiring diagram:

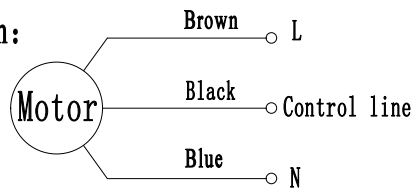

Black line open: n1 speed

Black line connect with blue line or brown line: n2 speed

Technical requirements:

1. Fan flexible rotation, no clamping stagnation, abnormal sound and other bad phenomenon;
2. No oil and glue mark on the surface of the fan, no defects such as obvious deformation, mechanical mar, etc;
3. Lead wires surface without damage, the length according to the requirements of the drawings;
4. The motor is BLDC, its protection functions include blocking protection, soft start, current-limiting protection;
5. Rotation direction: The fan rotates ccw viewed from rotor;
6. 2 speeds programmed through NFC;
7. Main technical parameters of the fan according to the preceding table:

						Hangzhou Weiguang Electronic Co., LTD.		
						ECM+ energy-saving fan		
Mark	Number	Partition	Change the file number	Signature	Date	Phase marker	Weight	Proportion
Design			Standardization					1:1
Examine								
Technology			Approval			Total 1 piece	Article 1 piece	EC072/13E3G01-AS172/45P1-01
						E0434P1		