

EVJ 500 series

Temperature/humidity and food processing controllers

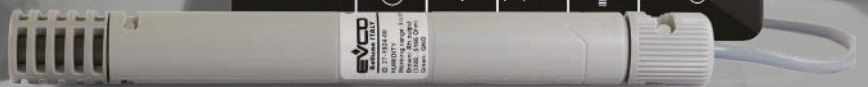
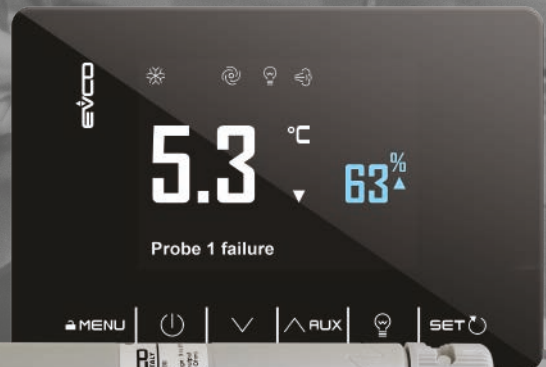

WARNING

Read and fully understand user manual before using this device.

Failure to follow these instructions can result in death, serious injury.



IMPORTANT INFORMATION	5
IMPORTANT SAFETY INFORMATION	6
SAFETY INFORMATION RELATING TO THE PRODUCT	7
1. INTRODUCTION	8
1.1 Description	8
1.2 Models available	8
1.3 Features	8
1.4 Accessories	8
2. TECHNICAL SPECIFICATIONS	10
2.1 Technical specifications	10
2.1.1 EVJ 506 / EVJ 526	10
2.1.2 EVJ 536	10
2.2 I/O features	11
2.2.1 EVJ 506	11
2.2.2 EVJ 526	12
2.2.3 EVJ 536	13
3. MECHANICAL ASSEMBLY	14
3.1 Before starting	14
3.2 Information on installation and the environment	14
3.3 Dimensions	15
3.4 Installation	15
3.4.1 Minimum distances	16
4. ELECTRICAL CONNECTIONS	17
4.1 WIRING BEST PRACTICES	17
4.1.1 Wiring guidelines	17
4.1.2 Fixed screw terminal blocks guidelines	17
4.1.3 Permitted lengths of wiring	18
4.2 Wiring diagram	18
5. USER INTERFACE	19
5.1 INTERFACE	19
5.2 TOUCH KEYS	19
5.3 ICONS	19
5.4 CONTROLLER OPERATION	20
5.4.1 Switching the controller ON/OFF	20
5.4.2 Selecting a pre-set programme (EVJ 536 only)	20
5.4.3 Changing the pre-set programme during operation (EVJ 536 only)	21
5.4.4 Functions that can be activated by key	21
5.4.5 Changing the setpoint	22
5.4.6 Stopping a cycle in progress (EVJ 536 only)	23



CONTENTS

5.4.7	Setting the clock	23
5.4.8	Accessing the parameters	24
5.4.9	Programming menu	25
6.	DEFROST	26
6.1	Introduction	26
6.1.1	Operating conditions	26
6.1.2	Dripping interval	26
6.1.3	Types of defrost	27
6.2	MODULAR DEFROST: RTC	27
6.3	STANDARD DEFROST	27
6.3.1	Defrost with electrical heaters	27
6.3.2	Defrost with cycle reversed (hot gas)	29
6.3.3	Defrost when compressor stops	31
7.	REGULATORS	32
7.1	HEATING/COOLING TEMPERATURE	32
7.1.1	Operation	32
7.2	HEATING/COOLING TEMPERATURE IN THE NEUTRAL ZONE	32
7.2.1	Operation	32
7.3	TEMPERATURE AND DEHUMIDIFICATION WITH THE COMPRESSOR	33
7.3.1	Operation	33
7.3.2	Temperature priority over dehumidification	33
7.4	HUMIDITY	33
7.4.1	Operation	33
7.5	HUMIDITY IN THE NEUTRAL ZONE	34
7.5.1	Operation	34
7.6	Compressor	34
7.6.1	Operating diagrams	35
7.7	DOUBLE COMPRESSOR	36
7.7.1	Operating Diagram	36
7.8	EVAPORATOR FANS	37
7.8.1	Regulator operation	37
7.8.2	Operating mode	37
7.8.3	Operation during defrost	37
7.8.4	Fan operation during dripping	37
7.9	CONDENSER FANS	38
7.9.1	Operation	38
7.10	ENERGY SAVING	38
7.10.1	Operation	38
8.	FUNCTIONS	39
8.1	SANITATION (EVJ 526 ONLY)	39



CONTENTS

8.2 AGING (EVJ 536 ONLY)	39
8.3 COPYING THE PARAMETERS	40
8.3.1 Introduction	40
8.3.2 Uploading the parameters from the controller to EVJKEY	40
8.3.3 Downloading the parameters from EVJKEY to the controller	40
9. PARAMETERS	41
9.1 TABLE OF CONFIGURATION PARAMETERS	41
10. DIAGNOSTICS	47
10.1 TABLE OF ALARMS	47

IMPORTANT INFORMATION

Liability and residual risks

EVCO assumes no liability for any damage caused by the following (by way of example; this is not an exhaustive list):

- Installation/use for purposes other than those specified and, in particular, not adhering to the safety provisions set out by current regulations in the country in which the product is installed and/or contained in this manual;
- Use in appliances that do not guarantee sufficient protection against electric shocks, water and dust within the installation conditions created;
- Use in appliances that allow access to hazardous parts without the use of a keyed or tooled locking mechanism when accessing the instrument;
- Tampering and/or modifying the product;
- Installation/use in appliances which do not comply with current regulations in the country in which the product is installed.

The customer/manufacturer is responsible for ensuring their machine complies with these regulations.

EVCO's responsibility is limited to the correct and professional use of the product in accordance with regulations and the instructions contained in this manual and other product support documents.

To comply with EMC standards, observe all the electrical connection instructions. As it depends on the wiring configuration as well as the load and the installation type, compliance must be verified for the final machine as specified by the relevant product standard.

Disclaimer

This document is the exclusive property of EVCO. It contains a general description and/or a description of the technical specifications for the features offered by the products listed herein. This document should not be used to determine the suitability or reliability of these products in relation to specific user applications. Each user or integration specialist should conduct their own complete and appropriate risk analysis, in addition to carrying out a product evaluation and test in relation to its specific application or use. Users can send us comments and suggestions on how to improve or correct this publication.

Neither EVCO nor any of its associates or subsidiaries shall be held responsible or liable for improper use of the information contained herein.

EVCO has a policy of continuous development, therefore reserves the right to make changes and improvements to any product described in this document without prior notice.

The images in this document and other documentation supplied with the product are provided for illustrative purposes only and may differ from the product itself.

The technical data in this manual is subject to change without prior notice.

Terms and Conditions of use

Permitted use

The device must be installed and used in accordance with the instructions provided and, in particular, hazardous live parts must not be accessible under normal conditions.

The device must be suitably protected from water and dust with regard to its application and must also only be accessible with the aid of a tool (with the exception of the front panel).

Only qualified personnel may install the product or perform technical support procedures on it.

The customer must only use the product as described in the documentation relating to that product.

Prohibited use

Any use other than those described in the "**Permitted use**" section and in the product support documentation is prohibited.

Disposal



The device must be disposed of according to local regulations governing the collection of electrical and electronic equipment.

Consider the environment



The company strives to respect the environment, taking account of customer requirements, technological innovations in terms of materials and the expectations of the community to which we belong. EVCO places great importance on respecting the environment, encouraging all associates to become involved with company values and guaranteeing safe, healthy and functional working conditions and workplaces.

Please consider the environment before printing this document.

IMPORTANT SAFETY INFORMATION

Read this document carefully before installation and take all precautions before using the device. Only use the device in accordance with the methods described in this document. The following safety messages may be repeated several times in the document, to provide information regarding potential hazards or to attract attention to information which may be useful in explaining or clarifying a procedure.



This symbol is used to indicate a risk of electric shock.
It is a safety indication and as such, should be observed to avoid potential accidents or fatalities.



This symbol is used to indicate a risk of serious personal injury.
It is a safety indication and as such, should be observed to avoid potential accidents or fatalities.

DANGER

DANGER indicates a situation of imminent danger which, if not avoided, **will result in death or serious injury.**

WARNING

WARNING indicates a situation of imminent danger which, if not avoided, **may result in death or serious injury.**

CAUTION

CAUTION indicates a potentially hazardous situation which, if not avoided, **could cause minor or moderate injury.**

NOTICE

NOTICE indicates a situation not related to physical injuries but which, if not avoided, could damage the equipment.

N.B. The maintenance, repair, installation and use of electrical equipment must only be entrusted to qualified personnel.

QUALIFIED PERSONNEL

Only suitably trained and experienced personnel capable of understanding the content of this manual and all documentation regarding the product are authorised to work on and with this equipment. Furthermore, the personnel must have completed courses in safety and must be able to recognise and prevent the implied dangers. The personnel must have suitable training, knowledge and experience at a technical level, and be capable of anticipating and detecting potential risks caused by using the product, as well as changing the settings and modifying the mechanical, electric and electronic equipment for the entire system in which the product is used. All personnel working on and with the product must be entirely familiar with the relevant standards and directives, as well as safety regulations.

SAFETY INFORMATION RELATING TO THE PRODUCT

Before carrying out any work on the equipment, read these instructions carefully, making sure you understand everything.

DANGER

RISK OF ELECTRIC SHOCK, EXPLOSION OR ELECTRIC ARC

- Only use electrically insulated measuring devices and equipment.
- Do not install the equipment while the power supply is connected.
- Switch off all equipment, including connected devices, before installing or uninstalling the device.
- Always use a correctly calibrated voltmeter to check the system is switched off.
- Do not touch the unshielded components or the terminals while they are live.
- Do not open, disassemble, repair or modify the product.
- Do not expose the equipment to liquids or chemicals.
- All 12...24 Vac/dc models must be individually powered.
- Before applying voltage to the equipment:
 - Make sure all protective elements, such as covers, hatches and grilles, are fitted and/or closed.
 - Check all wiring connections.

DANGER

RISK OF ELECTRIC SHOCK AND FIRE

- Do not use the device with loads greater than those indicated in the technical specifications.
- Do not exceed the temperature and humidity ranges indicated in the technical specifications.
- Use the required safety interlocks (fuses and/or magnetothermal switches) of a suitable size.

DANGER

RISK OF ELECTRIC SHOCK OR MALFUNCTIONING OF THE EQUIPMENT

Do not use damaged products or accessories.

This device was designed to operate in non-hazardous environments, excluding applications that generate, or could potentially generate, hazardous atmospheres. Only install this device in areas and for applications which are reliably free from hazardous atmospheres.

DANGER

RISK OF EXPLOSION

- Only install and use this device in sites that are not at risk.
- Do not install or use this device in applications which are capable of generating hazardous atmospheres, such as applications that use flammable refrigerants.

WARNING

MALFUNCTIONING OF THE EQUIPMENT

- Perform the wiring carefully, in compliance with electromagnetic compatibility requirements.
- Make sure the wiring is correct for the application.
- Use shielded cables for all I/O signal and communication cables.
- Minimise the length of the connections as much as possible and avoid winding the cables around electrically connected parts.
- The signal cables (analogue and digital inputs, communication and corresponding power supplies), power cables and power supply cables for the device must be routed separately.
- Before applying the power supply, check all the wiring connections.
- Use the required safety interlocks where personnel and/or equipment hazards exist.
- Install and operate this equipment in a cabinet appropriately rated for its intended environment and secured by a keyed or tooling locking mechanism.
- Power line and output circuits must be wired and fused in compliance with local and national regulatory requirements for the rated current and voltage of the particular equipment.
- Do not use this equipment in safety-critical machine functions.
- Do not disassemble, repair or modify this equipment.
- Do not connect wires to unused terminals and/or to terminals labelled "No connection (N.C.)".

1. INTRODUCTION

1.1 DESCRIPTION

The controllers in the **EVJ 500** series offer a complete range of EVCO solutions for managing:

- Temperature;
- Humidity;
- Food sanitation;
- Cabinet sterilisation and;
- Food aging.

1.2 MODELS AVAILABLE

The **EVJ 500** series consists of 3 controllers:

- **EVJ 506** - Temperature and humidity controller;
- **EVJ 526** - Temperature and humidity controller with sanitation function using UV lamps or ozone generators;
- **EVJ 536** - Temperature and humidity controller with food processing function.

1.3 FEATURES



The main features of the **EVJ 500** series are:

- 2 analogue inputs, of which:
 - 1 analogue input for temperature;
 - 1 analogue input for humidity;
- 2 voltage-free digital inputs, of which:
 - 1 digital input configurable as an analogue input by parameter;
- 6 unsealed relay outputs (can also be supplied sealed on request);
- 1 TTL serial;
- **EPoCA** compatible and;
- Compatible with BMS interface through the MODBUS protocol.

N.B. for more information about the features of the inputs and outputs, consult the section "**2.1 Technical specifications**" on page 10.

1.4 ACCESSORIES

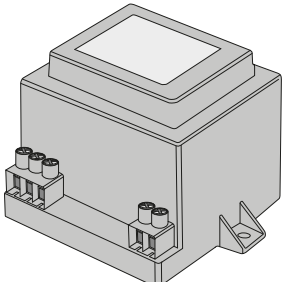
The **EVJ 500** series has the following accessories:

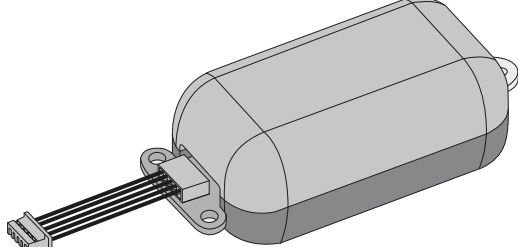
Type	P/n	Description
	3801000023	230/12 VAC insulated transformer
	---	Temperature probes NTC/PTC
	EVIF25TBX	BLE module to connect to the EVconnect app

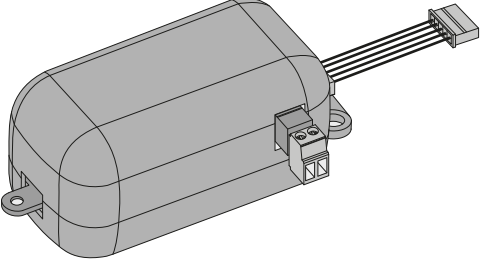
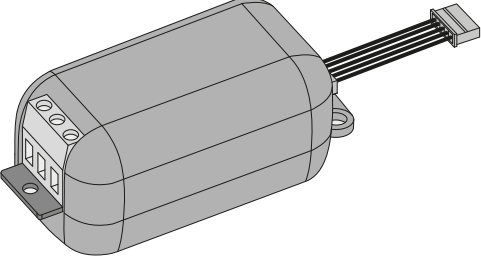
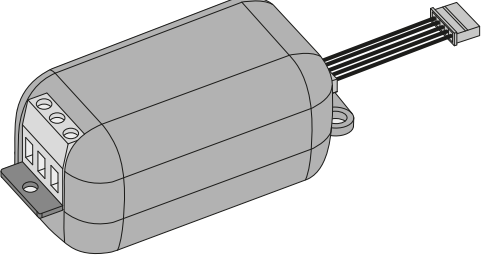
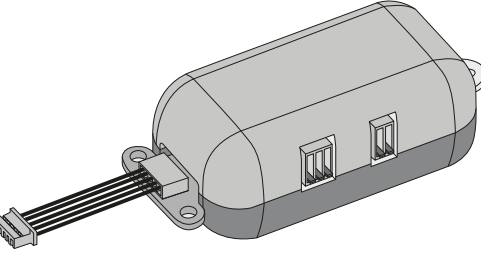
Type	P/n	Description
	EVIF25TWX	Wi-Fi module
	EVIF22TSX	Module for TTL/RS-485 serial interface
	EVIF23TSX	Module for TTL/RS-485 serial interface with built-in clock
	EVJKEY	Programming key for EVJ models.

2. TECHNICAL SPECIFICATIONS

All the system components of the **EVJ 500** controllers meet the requirements of the European Community (EC) for open equipment. They must be installed in a casing or other location designated for the specific ambient conditions and to keep the possibility of involuntary contact with dangerous electrical voltages to a minimum. Use metal casings to improve the immunity of the **EVJ 500** system to electromagnetic fields. This equipment meets EU requirements as shown in the tables below.

WARNING

MALFUNCTIONING OF THE EQUIPMENT

Do not exceed the nominal values given in this section.

2.1 TECHNICAL SPECIFICATIONS

2.1.1 EVJ 506 / EVJ 526

Type	Description
The product complies with the following harmonised standards:	EN60730-1 and EN60730-2-9
Device construction:	Built-in electronic device
Device purpose:	Operating control device
Type of action:	1
Pollution category:	2
Overvoltage category:	III
Rated impulse withstand voltage:	4000 V
Power supply:	12 Vac/dc, $\pm 10\%$, 50/60 Hz
Consumption:	10 VA maximum
Ambient operating conditions:	0 ... 55 °C (32 ... 131 °F) 10 ... 90 % RH non-condensing
Transportation and storage conditions:	-25 ... 70 °C (-13 ... 158 °F) 10 ... 90 % RH non-condensing
Software class:	A
Environmental front protection:	IP65
Clock (RTC):	Built-in lithium battery
Clock drift:	≤ 60 s/month at 25 °C (77 °F)
Battery life:	> 6 months at 25 °C (77 °F)
Battery charging time:	24 h through device's power supply

2.1.2 EVJ 536

Type	Description
The product complies with the following harmonised standards:	EN60730-1 and EN60730-2-9
Device construction:	Built-in electronic device
Device purpose:	Operating control device
Type of action:	1
Pollution category:	2
Overvoltage category:	III
Rated impulse withstand voltage:	4000 V
Power supply:	12 Vac/dc, $\pm 10\%$, 50/60 Hz
Consumption:	10 VA maximum
Ambient operating conditions:	0 ... 55 °C (32 ... 131 °F) 10 ... 90 % RH non-condensing
Transportation and storage conditions:	-25 ... 70 °C (-13 ... 158 °F) 10 ... 90 % RH non-condensing
Software class:	A
Environmental front protection:	IP65
Clock (RTC):	Built-in lithium battery
Clock drift:	≤ 60 s/month at 25 °C (77 °F)
Battery life:	> 6 months at 25 °C (77 °F)
Battery charging time:	24 h through device's power supply

2.2 I/O FEATURES

2.2.1 EVJ 506

Type	Description
Digital inputs:	2 voltage-free digital inputs (ID3 also configurable as analogue input Pb3 with Pr3≠0)
Analogue inputs for temperature:	2 analogue inputs for NTC or PTC or humidity probe
Digital output with non-hazardous voltage (SELV):	6 digital outputs
Serial:	1 TTL serial

Analogue input features

	Default	NTC 10 kΩ at 25 °C BETA 3435	PTC KTY 81-121 990 Ω at 25 °C	RH EVHTP5•0	Digital input
Pb1	Temperature probe	•	•	---	---
Pb2	Humidity probe (EVHTP5•0)	---	---	•	---
Pb3	(If Pr3=5) Evaporator probe	•	•	---	•
Range	---	-50...120 °C (-58...248 °F)	-50...150 °C (-58...302 °F)	5 ...95% RH	---
Resolution	---	0.1 °C (1 °F)		1 %	---
Input impedance	---	10 kΩ	990 Ω	---	---

Digital output features

Relay output	Default	Description	Load (at 250 Vac)	Type of load
Out1	Compressor	SPST	30 A	Resistive
Out2	Heating	SPDT	8 A	Resistive
Out3	Light	SPST	16 A	Resistive
Out4	Humidification	SPST	8 A	Resistive
Out5	Fans	SPST	5 A	Resistive
Out6	Defrost	SPDT	8 A	Resistive

2.2.2 EVJ 526

Type	Description
Digital inputs:	2 voltage-free digital inputs (ID3 also configurable as analogue input Pb3 with Pr3≠0)
Analogue inputs for temperature:	2 analogue inputs for NTC or PTC or humidity probe
Digital output with non-hazardous voltage (SELV):	6 digital outputs
Serial:	1 TTL serial

Analogue input features

	Default	NTC 10 kΩ at 25 °C BETA 3435	PTC KTY 81-121 990 Ω at 25 °C	RH EVHTP5•0	Digital input
Pb1	Temperature probe	•	•	---	---
Pb2	Humidity probe (EVHTP5•0)	---	---	•	---
Pb3	(If Pr3=5) Evaporator probe	•	•	---	•
Range	---	-50...120 °C (-58...248 °F)	-50...150 °C (-58...302 °F)	5 ...95% RH	---
Resolution	---	0.1 °C (1 °F)		1 %	---
Input impedance	---	10 kΩ	990 Ω	---	---

Digital output features

Relay output	Default	Description	Load (at 250 Vac)	Type of load
Out1	Compressor	SPST	30 A	Resistive
Out2	Heating	SPDT	8 A	Resistive
Out3	Light	SPST	16 A	Resistive
Out4	Humidification	SPST	8 A	Resistive
Out5	Fans	SPST	5 A	Resistive
Out6	Defrost	SPDT	8 A	Resistive

2.2.3 EVJ 536

Type	Description
Digital inputs:	2 voltage-free digital inputs (ID3 also configurable as analogue input Pb3 with Pr3≠0)
Analogue inputs for temperature:	2 analogue inputs for NTC or PTC or humidity probe
Digital output with non-hazardous voltage (SELV):	6 digital outputs
Serial:	1 TTL serial

Analogue input features

	Default	NTC 10 kΩ at 25 °C BETA 3435	PTC KTY 81-121 990 Ω at 25 °C	RH EVHTP520	Digital input
Pb1	Temperature probe	•	•	---	---
Pb2	Humidity probe (EVHTP520)	---	---	•	---
Pb3	(If Pr3=5) Evaporator probe	•	•	---	•
Range	---	-50...120 °C (-58...248 °F)	-50...150 °C (-58...302 °F)	5 ...95% RH	---
Resolution	---	0.1 °C (1 °F)		1 %	---
Input impedance	---	10 kΩ	990 Ω	---	---

Digital output features

Relay output	Default	Description	Load (at 250 Vac)	Type of load
Out1	Compressor	SPST	30 A	Resistive
Out2	Heating	SPDT	8 A	Resistive
Out3	Light	SPST	16 A	Resistive
Out4	Humidification	SPST	8 A	Resistive
Out5	Fans	SPST	5 A	Resistive
Out6	Defrost	SPDT	8 A	Resistive

3. MECHANICAL ASSEMBLY

3.1 BEFORE STARTING

Read this manually carefully before installing the system.

In particular, the safety instructions, electrical requirements and current regulations for the machine or the process in which this device is involved must be observed. The use and application of the information contained herein require experience in the design and programming of automated control systems. Only the user, system integrator or machine builder can be aware of all the conditions and factors present during the installation, configuration, operation and maintenance of the machine or process, and can therefore determine the associated automation equipment and the related safeties and interlocks which can be effectively and properly used. When selecting automation and control equipment and any other related equipment or software for a particular application, always consider all the applicable local, regional or national standards and/or regulations.

WARNING

REGULATORY NON-COMPLIANCE

Make sure all the equipment used and the systems comply with all the applicable local, regional and national regulations.

3.2 INFORMATION ON INSTALLATION AND THE ENVIRONMENT

Before carrying out any work on the equipment, read these instructions carefully, making sure you understand everything.

DANGER

RISK OF ELECTRIC SHOCK, EXPLOSION OR ELECTRIC ARC

- Only use electrically insulated measuring devices and equipment.
- Do not install the equipment while the power supply is connected.
- Switch off all equipment, including connected devices, before installing or uninstalling the device.
- Always use a correctly calibrated voltmeter to check the system is switched off.
- Do not touch the unshielded components or the terminals while they are live.
- Do not open, disassemble, repair or modify the product.
- Do not expose the equipment to liquids or chemicals.
- Before applying voltage to the equipment:
 - Make sure all protective elements, such as covers, hatches and grilles, are fitted and/or closed.
 - Check all wiring connections.

This device was designed to operate in non-hazardous environments, excluding applications that generate, or could potentially generate, hazardous atmospheres. Only install this device in areas and for applications which are reliably free from hazardous atmospheres.

DANGER

RISK OF EXPLOSION

- Only install and use this device in sites that are not at risk.
- Do not install or use this device in applications which are capable of generating hazardous atmospheres, such as applications that use flammable refrigerants.

⚠ WARNING

MALFUNCTIONING OF THE EQUIPMENT

- Perform the wiring carefully, in compliance with electromagnetic compatibility and safety requirements.
- Make sure the wiring is correct for the application.
- Use shielded cables for all I/O signal and communication cables.
- Minimise the length of the connections as much as possible and avoid winding the cables around electrically connected parts.
- The signal cables (analogue and digital inputs, communication and corresponding power supplies), power cables and power supply cables for the device must be routed separately.
- Before applying the power supply, check all the wiring connections.
- Use the required safety interlocks where personnel and/or equipment hazards exist.
- Install and operate this equipment in a cabinet appropriately rated for its intended environment and secured by a keyed or toolled locking mechanism.
- Power line and output circuits must be wired and fused in compliance with local and national regulatory requirements for the rated current and voltage of the particular equipment.
- Do not use this equipment in safety-critical machine functions.
- Do not disassemble, repair or modify this equipment.
- Do not connect wires to unused terminals and/or to terminals labelled "No connection "(N.C.)".

3.3 DIMENSIONS



Fig. 1. EVJ 500 series dimensions

3.4 INSTALLATION

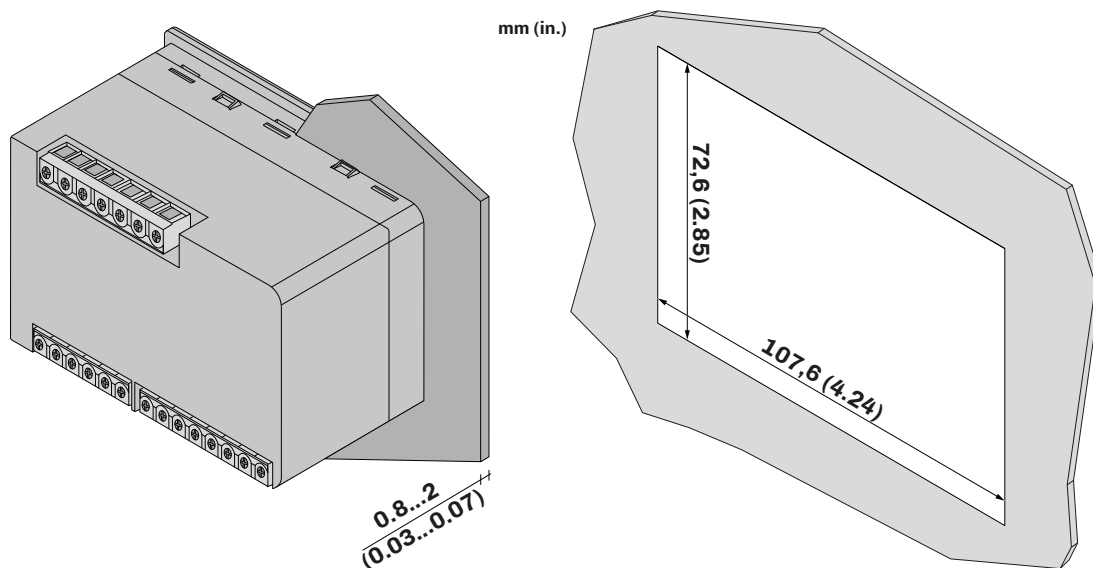

Fig. 2. EVJ 500 series installation

3.4.1 Minimum distances

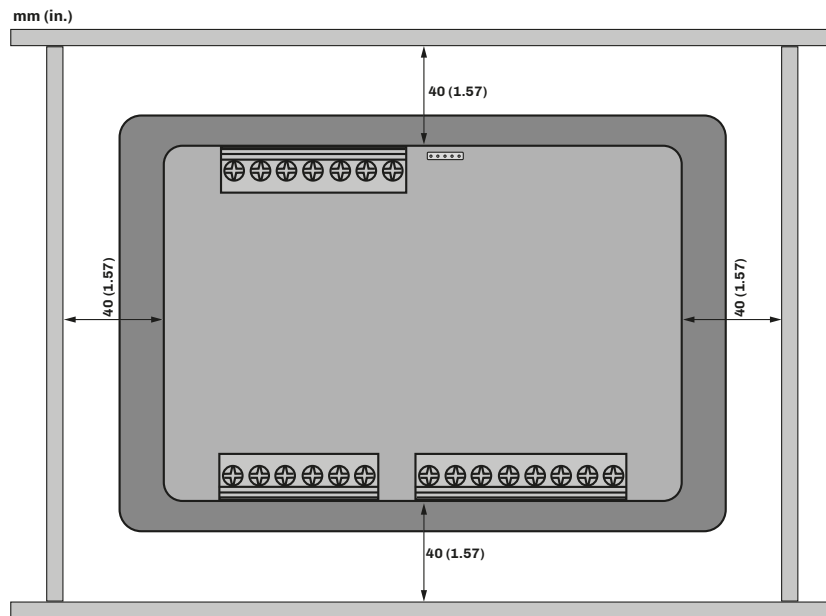

Fig. 3. EVJ 500 series minimum installation distances

4. ELECTRICAL CONNECTIONS

4.1 WIRING BEST PRACTICES

The following information describes the wiring guidelines and best practices which should be observed when using the equipment described in this manual.

DANGER

RISK OF ELECTRIC SHOCK, EXPLOSION OR ELECTRIC ARC

- Only use electrically insulated measuring devices and equipment.
- Do not install the equipment while the power supply is connected.
- Switch off all equipment, including connected devices, before installing or uninstalling the device.
- Always use a correctly calibrated voltmeter to check the system is switched off.
- Do not touch the unshielded components or the terminals while they are live.
- Do not open, disassemble, repair or modify the product.
- Do not expose the equipment to liquids or chemicals.
- Before applying voltage to the equipment:
 - Make sure all protective elements, such as covers, hatches and grilles, are fitted and/or closed.
 - Check all wiring connections.

4.1.1 Wiring guidelines

When wiring the controllers, observe the following instructions:

- The I/O and communication wiring must be kept separate from the power supply wiring. These two types of wiring must be routed in separate ducts.
- Make sure the operating environment and conditions fall within the specified values.
- Use wires with the correct diameter, suited to the voltage and current requirements.
- Use copper conductors (compulsory).
- Use shielded twisted pair cables for analogue/digital I/O connections.

Use correctly earthed shielded cables for all analogue inputs or outputs and for communication connections. If shielded cables are not used for these connections, electromagnetic interference could cause the signal to deteriorate. Deteriorated signals can lead to unpredictable operation of the controller or modules and connected equipment.

WARNING

MALFUNCTIONING OF THE EQUIPMENT

- Perform the wiring carefully, in compliance with electromagnetic compatibility and safety requirements.
- Make sure the wiring is correct for the application.
- Use shielded cables for all I/O signal and communication cables.
- Minimise the length of the connections as much as possible and avoid winding the cables around electrically connected parts.
- The signal cables (analogue and digital inputs, communication and corresponding power supplies), power cables and power supply cables for the device must be routed separately.
- Before applying the power supply, check all the wiring connections.
- Use the required safety interlocks where personnel and/or equipment hazards exist.
- Install and operate this equipment in a cabinet appropriately rated for its intended environment and secured by a keyed or tooled locking mechanism.
- Power line and output circuits must be wired and fused in compliance with local and national regulatory requirements for the rated current and voltage of the particular equipment.
- Do not use this equipment in safety-critical machine functions.
- Do not disassemble, repair or modify this equipment.
- Do not connect wires to unused terminals and/or to terminals labelled "No connection (N.C.)".

4.1.2 Fixed screw terminal blocks guidelines

Suitable wiring for power supply and I/O SELV

Passo 5,08 mm (0.199 in.)









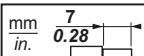

												N•m	0.5...0.6
mm in.	7 0.28									Ø 3.5 mm (0.14 in.)		lb-in	4.42...5.31
mm ²	0.2...2.5	0.2...2.5	0.25...2.5	0.25...2.5	2 x 0.2...1	2 x 0.2...1.5	2 x 0.25...1	2 x 0.5...1.5					
AWG	24...14	24...14	22...14	22...14	2 x 24...18	2 x 24...16	2 x 22...18	2 x 20...16					

Fig. 4. Suitable wiring for power supply and I/O SELV

4.1.3 Permitted lengths of wiring

NOTICE

DEVICE NOT WORKING

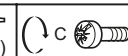
- When connecting the probes, the digital inputs and the power supply, use cables with a maximum length of 10 m (32.80 ft).
- When connecting the TTL serial, use cables with a maximum length of 1 m (3.28 ft).
- When connecting the power supply of the controller and the relay outputs, use cables with a maximum length of 10 m (32.80 ft).

4.2 WIRING DIAGRAM

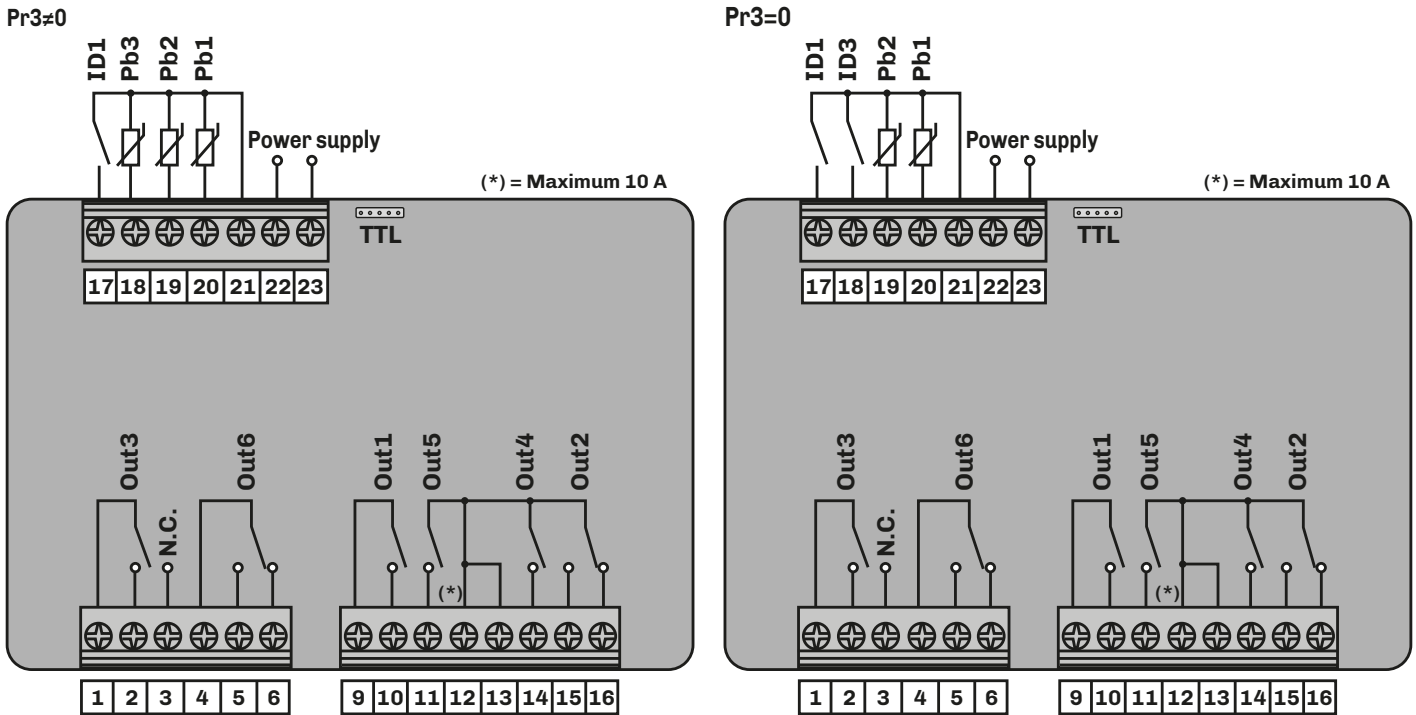

Fig. 5. Wiring diagram

TERMINALS			
1-2	Relay output Out3 (Light)	12-15-16	Relay output Out2 (Heating)
3	No connection N.C.	17-21	Digital input ID1
4-5-6	Relay output Out6 (Defrost)	18-21	Digital input ID3 if $Pr3=0$ Probe input Pb3 if $Pr3 \neq 0$
8-10	Relay output Out1 (Compressor)	19-21	Probe input Pb2 (Humidity)
11-12	Relay output Out5 (Fans)	20-21	Probe input Pb1 (Temperature)
12-14	Relay output Out4 (Humidification)	22-23	Power supply input

5. USER INTERFACE

5.1 INTERFACE

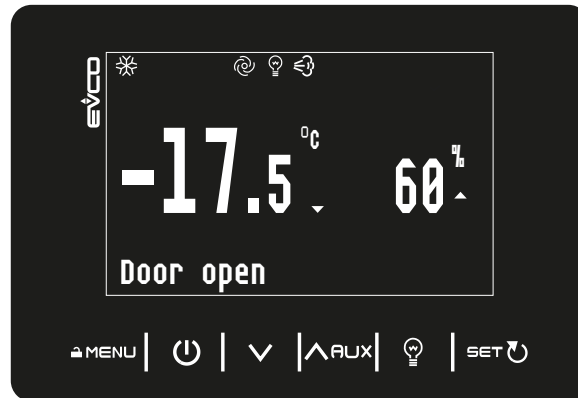

Fig. 6. User interface

5.2 TOUCH KEYS

A description of the touch keys is given below:

Key...	Press and release to...	Press for at least 3 seconds to...
MENU	---	<ul style="list-style-type: none"> • (From home page) Access the configuration menu • (From stand-by) Access the programming menu
	<ul style="list-style-type: none"> • Go back one level • Exit a function 	<ul style="list-style-type: none"> • Switch device on/off • Stop regulation
V	<ul style="list-style-type: none"> • Decrease a value • Move within a menu 	---
AUX	<ul style="list-style-type: none"> • Increase a value • Move within a menu • Access the AUX menu 	---
	Active/Deactivate the light relay output	---
SET	<ul style="list-style-type: none"> • Confirm a selected value/function • Access the setpoint menu 	---

5.3 ICONS

Icon	ON	Flashing	OFF
	<ul style="list-style-type: none"> • Cooling request • Dehumidification request 	Protection delay ON	Compressor OFF
	Defrost active	<ul style="list-style-type: none"> • Defrost delay ON • Dripping ON 	---
	Evaporator fans ON	<ul style="list-style-type: none"> • Evaporator fan activation delay ON • Humidification/dehumidification cycle ON 	Evaporator fans OFF
	<ul style="list-style-type: none"> • Humidification request • Humidification digital output ON 	---	---
	<ul style="list-style-type: none"> • Dehumidification request • Dehumidification digital output ON 	Dehumidification delay with compressor ON	---
	<ul style="list-style-type: none"> • Heating request • Heating digital output ON 	---	---
HACCP	HACCP alarm saved	New HACCP alarm recorded	---
	Energy saving ON	---	Energy saving OFF
	Maintenance request	Remote connection	---
C	Temperature displayed in °C	---	---
F	Temperature displayed in °F	---	---
%	Humidity displayed in %	---	---
AUX	<ul style="list-style-type: none"> • AUX function ON • AUX digital output ON 	---	AUX function OFF

Icon	ON	Flashing	OFF
	Light relay ON by key	Light relay ON by door switch	Light relay OFF
	---	Alarm in progress	---
	<ul style="list-style-type: none"> Probe value below the setpoint Probe value above the setpoint 	---	---
	Keypad locked	---	---
	Keypad unlocked	---	---
	Door switch open	Door switch closed	---
	Active cycle	Cycle suspended due to activation of other function	Inactive cycle
	EVJ 526 ONLY Sanitation in progress with device ON	Sanitation interval (if device is ON)	

5.4 CONTROLLER OPERATION

5.4.1 Switching the controller ON/OFF

To switch the controller on/off, press the key for at least 3 seconds.



Fig. 7. Main screen

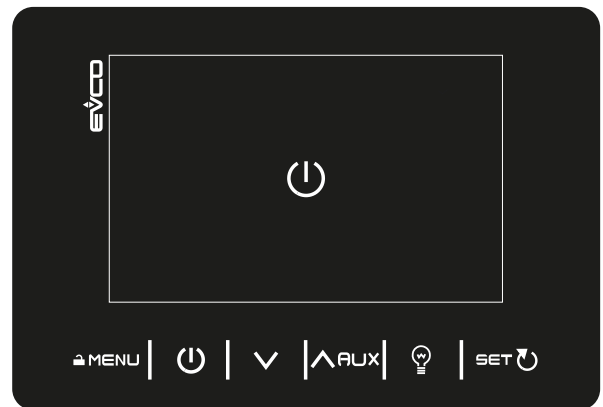

Fig. 8. Controller switching off

N.B.: the icon will be displayed for a few seconds as shown in "Fig. 8. Controller switching off" on page 20 and then the display will go off. The icon will be displayed when one of the keys is pressed.

5.4.2 Selecting a pre-set programme (EVJ 536 only)

To select one of the six pre-set operating programmes:

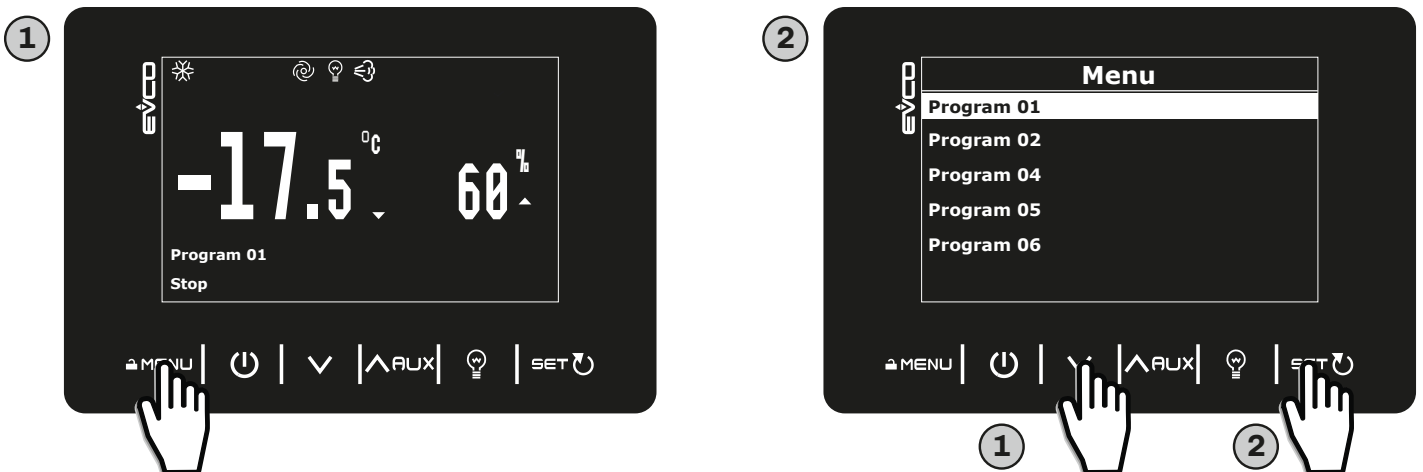

Fig. 9. Selecting the operating programme

5.4.3 Changing the pre-set programme during operation (EVJ 536 only)

To change the pre-set programme during operation:



Fig. 10. Changing the programme during operation

Enter the current programme (in "Fig. 10. Changing the programme during operation" on page 21 "Program 01") and use the ∇ or \wedge AUX keys to scroll through and choose the function to change.

5.4.4 Functions that can be activated by key

The following functions in the EVJ 500 series can be activated by touching the \wedge AUX key:

- **Sanitation**, this activates the sanitation function (EVJ 526 only);
- **Defrost**, this activates defrost if all the conditions are met (see 6. DEFROST" on page 26);
- **Over temp**, this forces a setpoint 1 (temperature) different from the one set which is timed (visible if P30 = 0);
- **Extra rh**, this forces a setpoint 2 (humidity) different from the one set which is timed (visible if P30 = 0) (EVJ 506/EVJ 526 only);
- **Skip**, this skips a phase in the programme, going on to the next one (visible if P30 = 2) (EVJ 536 only);
- **Air**, this activates the air change function (visible if P30 = 2) (EVJ 536 only);
- **Resting**, this activates the resting function (visible if P30 = 2) (EVJ 536 only);
- **Energy saving**, this activates the energy saving function;
- **AUX**, this activates the AUX relay output.

Choose the function by touching the SET ∇ key and confirm by pressing the SET ∇ key again.

5.4.5 Changing the setpoint

To change the setpoint:

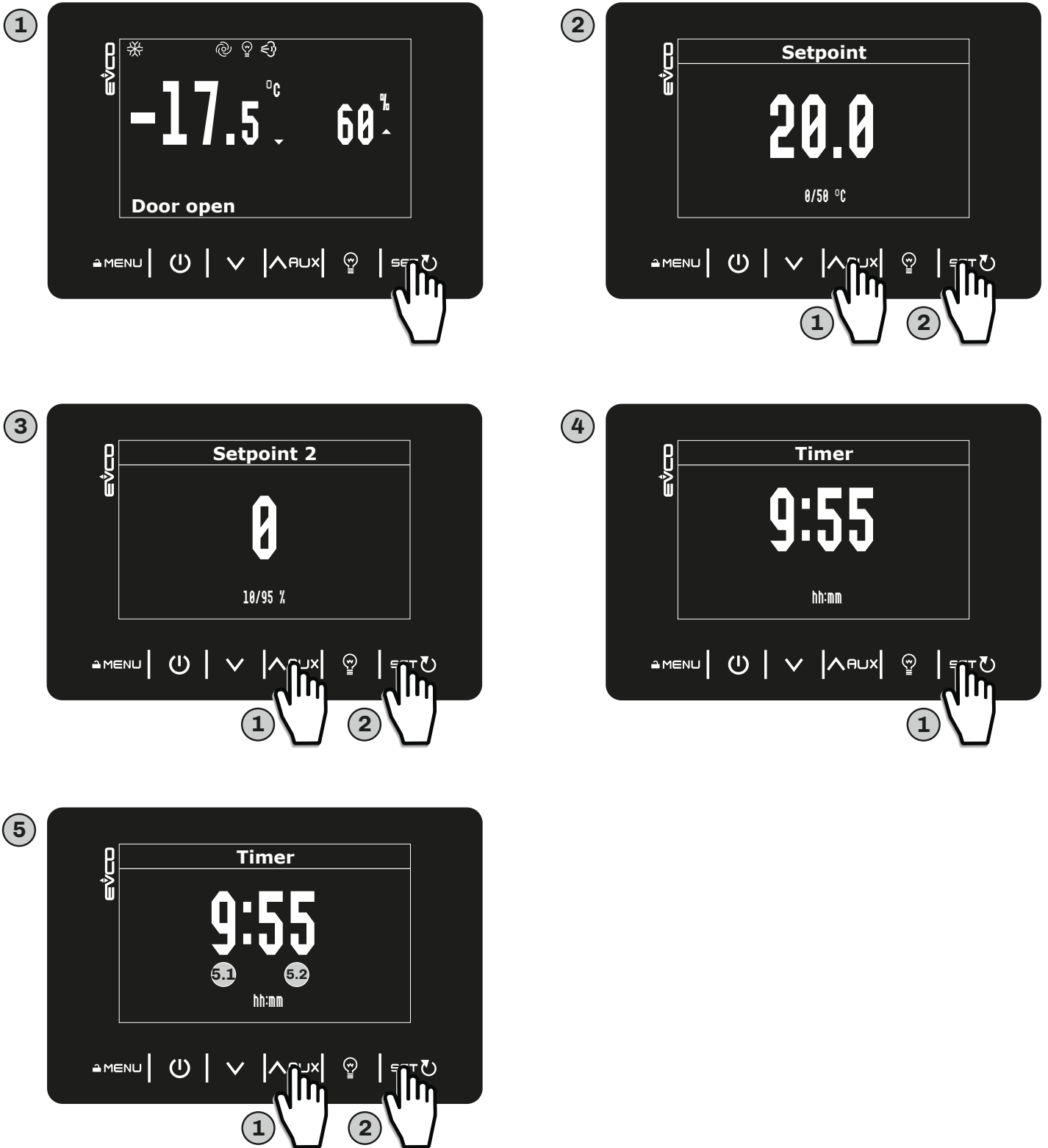

Fig. 11. Changing the setpoint

N.B. The timer can only be changed ((4) and (5)) in EVJ 536.

5.4.6 Stopping a cycle in progress (EVJ 536 only)

To stop a cycle in progress, touch the  key for at least 3 seconds. The message STOP will appear on the screen for a few seconds, as shown in "Fig. 12. Display when cycle is stopped" on page 23.



Fig. 12. Display when cycle is stopped

5.4.7 Setting the clock

To set the clock (date and time) on the device:

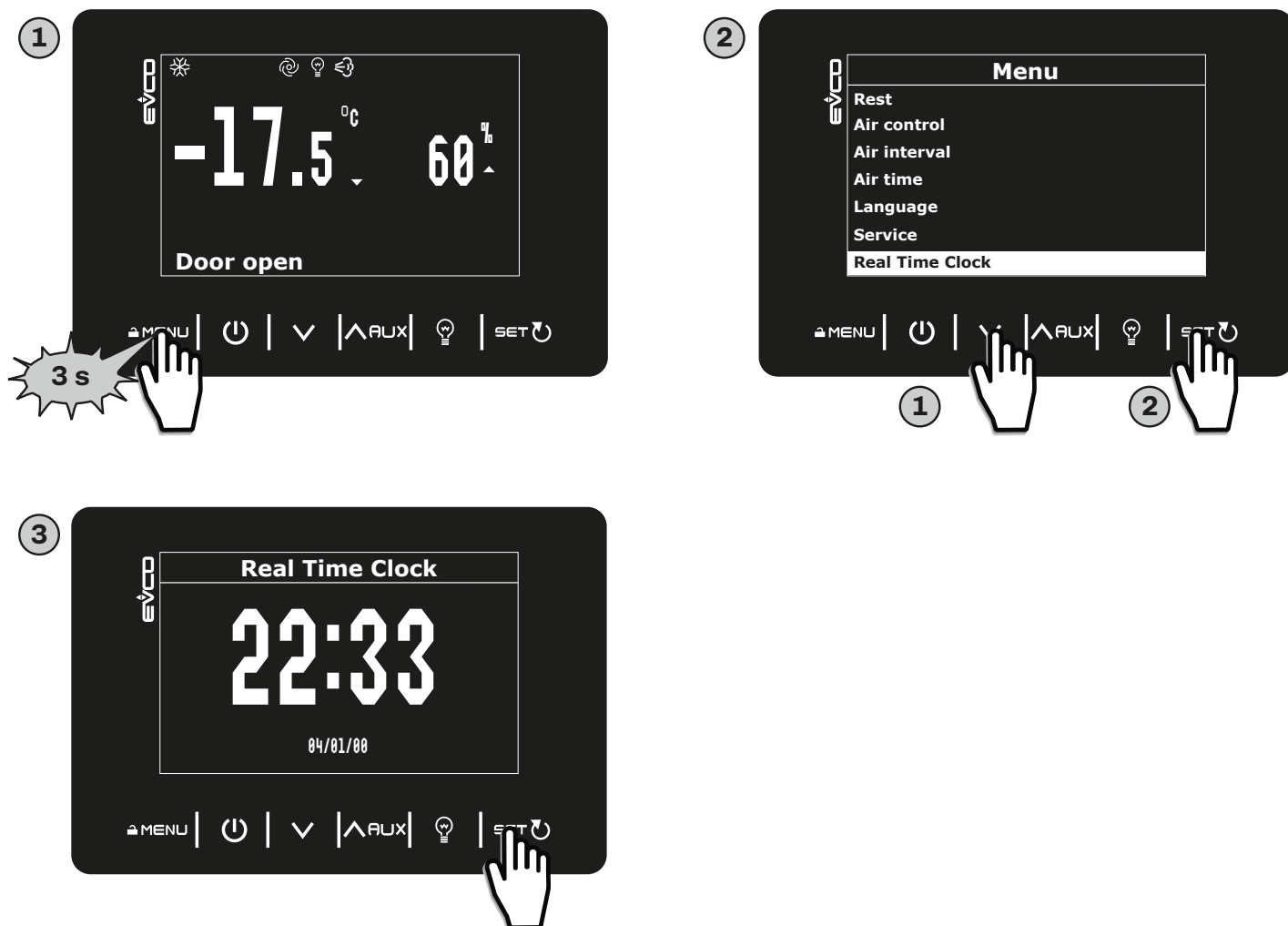



Fig. 13. Setting the clock

Touch the SET  key to set the clock in this order (to scroll, press SET ):

1. Year;
2. Month;
3. Day;
4. Hours;
5. Minutes.

5.4.8 Accessing the parameters

To access and change the parameters:

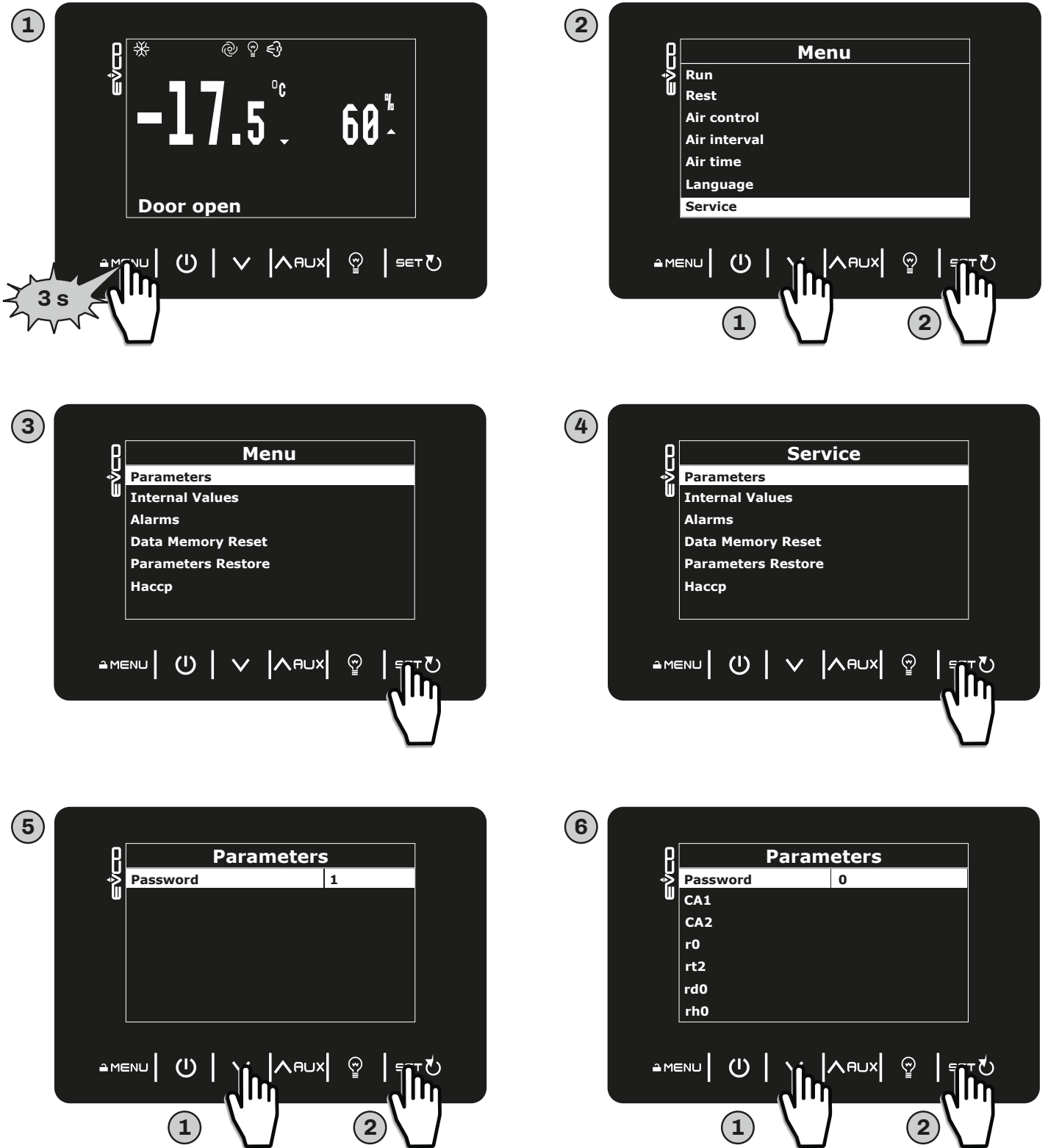

Fig. 14. Accessing the parameters

5.4.9 Programming menu

To access the programming menu, touch the **MENU** key for at least 3 seconds. The following options will be displayed:

- **Program 0x** ("x" depending on the programme in progress from 01...06);
- **Run** (EVJ 536 only);
- **Rest** (EVJ 536 only);
- **Air Control** (EVJ 536 only);
- **Air Interval** (EVJ 536 only);
- **Air Time** (EVJ 536 only);
- **Language**;
- **Service**;
- **Real Time Clock**.

Program 0x

The current programme is changed in this section. See "**5.4.3 Changing the pre-set programme during operation (EVJ 536 only)**" on page 21.

Run

The duration of the regulation is changed in this section:

- 0...99 h.

Rest

The duration of the pause from regulation at the end of dripping is set and changed in this section.

Air Control / Air Interval

In the **Air Control** section you can choose from the following options to set the air change mode:

- **0** = Activated in all 3 processes (default);
- **1** = Activated in processes 1 (dripping) and 2 (drying);
- **2** = Activated in processes 2 (drying) and 3 (aging);
- **3** = Activated in processes 1 (dripping) and 3 (aging).

The duration of the air change is set in the **Air Interval** section:

- 0...99 h.

Language

The language used by the controller is selected in this section. Choose from:

- English;
- Italian;
- German;
- French;
- Spanish;
- Polish;
- Traditional Chinese;
- Simplified Chinese.

Service

The following items are found in the service menu:

- **Parameters**, the list of parameters is accessed;
- **Internal Values**, the temperatures of the probes and their status are displayed;
- **Alarms**, the alarms in progress are displayed;
- **Data Memory Reset**, the factory data can be reset;
- **Parameters Restore**, the parameters can be reset to factory settings;
- **HACCP**, the HACCP alarms registered with their start date and time before the alarms were reset are displayed.

6. DEFROST

6.1 INTRODUCTION

Defrosting removes ice from the surface of the evaporator.

Defrost is set to manual mode by default **d0** = 0. For automatic mode, set **d0** > 0.

The defrost configuration parameters are:

Par.	Description	MU	Range
d0	Defrost interval.	h	0...99
d1	Type of defrost. 0 = Electrical heaters; 1 = Cycle reversed (hot gas); 2 = When compressor stops.	---	0...3
d2	Evaporator temperature above which defrost with evaporator probe terminates (Pr3 = 5).	°C/°F	-99.0...99.0
d3	Defrost duration.	min	0...99
d4	Enable defrost when device is switched on. 0 = No; 1 = Yes, activate defrost at switch-on; 2 = activate defrost after over-cooling; 3 = Activate defrost at switch-on and after over-cooling.	---	0...3
d5	Time between switching the device on and starting defrost.	min	0...99
d6	Value displayed during defrost. 0 = Regulation; 1 = Display locked; 2 = Unused.	---	0...2
d7	Evaporator dripping time after defrost.	min	0...15
d11	Enable warning defrost terminated due to maximum duration. 0 = No; 1 = Yes.	---	0/1
d13	Defrost during pause-work (resting). 0 = No; 1 = Yes. (EVJ 536 only).	---	0/1
d15	Compressor ON consecutive time before hot gas defrost.	min	0...99

Defrost starts up when the time set by **d0** has elapsed, in the mode set by **d1**.

Defrost duration is determined by **d3**, while the temperature threshold to end defrost is determined by **d2**, if **Pr3** = 5 (Evaporator probe active).

To keep the coils clean, forced defrost can be set by parameter **d4** when the controller is switched on.

Parameter **d5** sets a delay in minutes between switching the device on and starting up defrost.

With **d11** = 1, a message is displayed (**dFd**) if defrost lasts longer than **d3** (only if **Pr3** = 5).

(**EVJ 536** only) By setting parameter **d13** = 1, forced defrost takes place in the pause-work between drying phases.

With **d15** = 0, the function is disabled. If **d15** > 0 the compressor is forced to ON for the set time.

6.1.1 Operating conditions

Defrost starts up automatically if the following conditions are met:

- Pb3 temperature is below **d2**;
- **d0** interval has elapsed and Pb3 temperature is below **d2**.

If manual defrost is active or one of these two conditions is not met, defrost will **not** start up automatically.

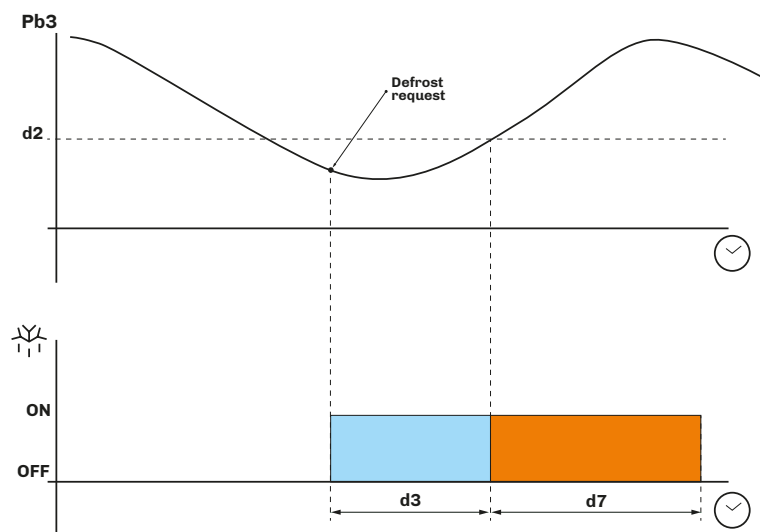

Fig. 15. Defrost with **Pr3** = 5

6.1.2 Dripping interval

It is possible to set a dripping interval at the end of a defrost cycle, by setting **d7** > 0, to prevent water building up in the evaporator, which could then freeze.

6.1.3 Types of defrost

The **EVJ 500** series has two types of defrost:

- Modular;
- Standard.

6.2 MODULAR DEFROST: RTC

If parameters **hd1...hd6** > 0, defrost is independent of the programme in progress and starts up at pre-set intervals and days. In the event of a clock alarm (RTC), defrost is activated according to the interval **d0**.

The defrost configuration parameters are:

Par.	Description	MU	Range
Hd1	Defrost 1 activation time. "----" = Disabled.	h	----, 0...23
Hd2	Defrost 2 activation time. "----" = Disabled.	h	----, 0...23
Hd3	Defrost 3 activation time. "----" = Disabled.	h	----, 0...23
Hd4	Defrost 4 activation time. "----" = Disabled.	h	----, 0...23
Hd5	Defrost 5 activation time. "----" = Disabled.	h	----, 0...23
Hd6	Defrost 6 activation time. "----" = Disabled.	h	----, 0...23

6.3 STANDARD DEFROST

Parameter **d1** must be set to use this mode.

Defrost is carried out by heating the evaporator in one of the following ways:

Par.	Description	MU	Range
d1	Type of defrost. 0 = Electrical heaters; 1 = Cycle reversed (hot gas); 2 = When compressor stops.	---	0...3

6.3.1 Defrost with electrical heaters

Defrost with electrical heaters is obtained by setting **d1** = 0.

Activating defrost

When defrost is activated:

- The compressor stops;
- The relay output, where the electrical heaters are connected and which is configured as the defrost output, is activated.

Conditions for defrost end

The conditions for defrost end are:

- Defrost duration **d3** must be reached;
- Temperature to end defrost **d2** must be reached.

The defrost configuration parameters with electrical heaters are:

Par.	Description	MU	Range
C0	Compressor ON delay from power-on.	min	0...240
C2	Minimum compressor OFF time.	min	0...240
d0	Defrost interval.	h	0...99
d1	Type of defrost. 0 = Electrical heaters; 1 = Cycle reversed (hot gas); 2 = When compressor stops.	---	0...3
d2	Evaporator temperature above which defrost with evaporator probe terminates (Pr3 = 5).	°C/°F	-99.0...99.0
d3	Defrost duration.	min	0...99
d7	Evaporator dripping time after defrost.	min	0...15

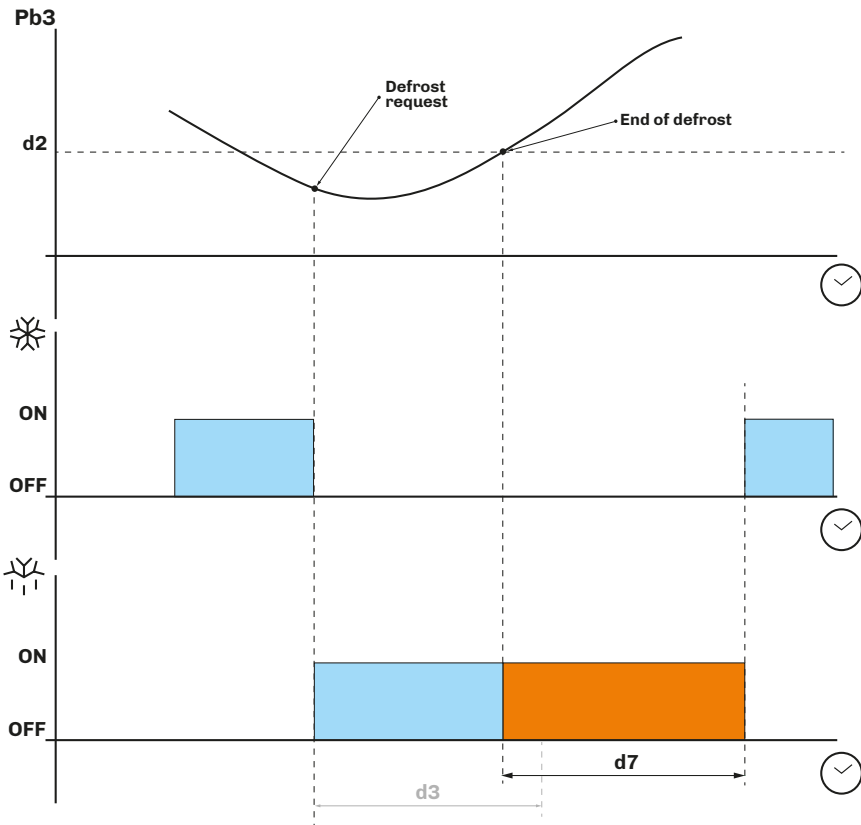

Fig. 16. Defrost with electrical heaters - End of defrost due to temperature

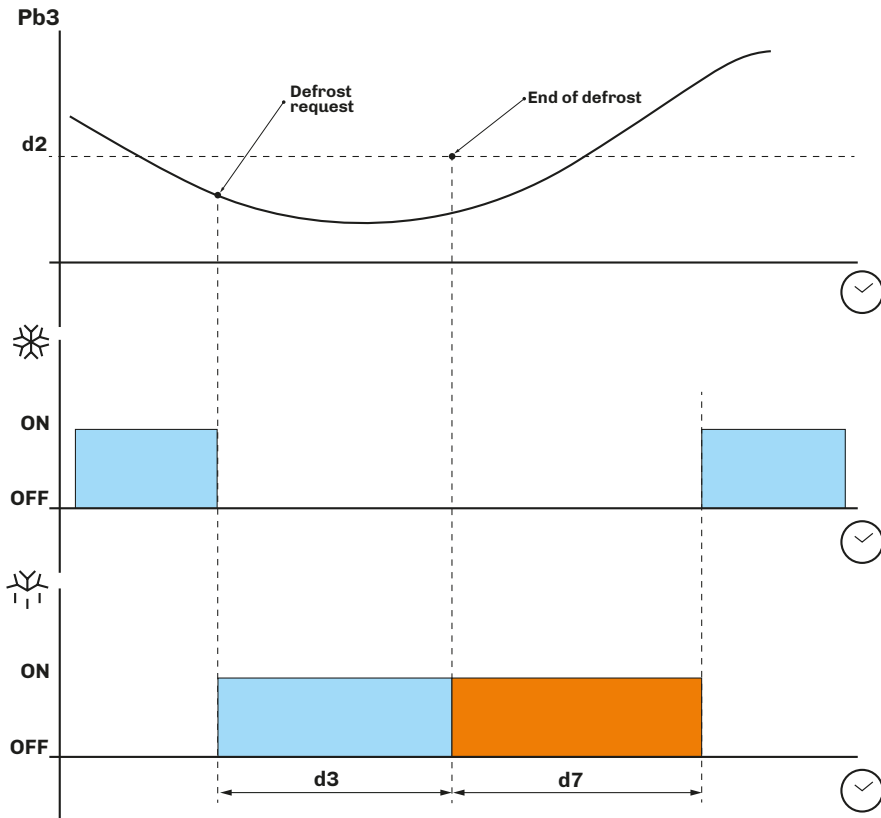

Fig. 17. Defrost with electrical heaters - End of defrost due to maximum time

6.3.2 Defrost with cycle reversed (hot gas)

Defrost with cycle reversed is obtained by setting **d1** = 1.

Activating defrost

When defrost is activated:

- The compressor is activated (or has already been active for time **d15**) and remains active for the entire duration of defrost;
- The relay output where the valve is connected (a solenoid valve if the system has a thermostatic valve) is activated.

Conditions for defrost end

The conditions for defrost end are:

- Maximum defrost duration, set by parameter **d3**, must be reached.
- Temperature to end defrost, set by parameter **d2**, must be reached.

The defrost configuration parameters with cycle reversed are:

Par.	Description	MU	Range
C0	Compressor ON delay from power-on.	min	0...240
C2	Minimum compressor OFF time.	min	0...240
d0	Defrost interval.	h	0...99
d1	Type of defrost. 0 = Electrical heaters; 1 = Cycle reversed (hot gas); 2 = When compressor stops.	---	0...3
d2	Evaporator temperature above which defrost with evaporator probe terminates (Pr3 = 5).	°C/°F	-99.0...99.0
d3	Defrost duration.	min	0...99
d7	Evaporator dripping time after defrost.	min	0...15
d15	Compressor ON consecutive time before hot gas defrost.	min	0...99

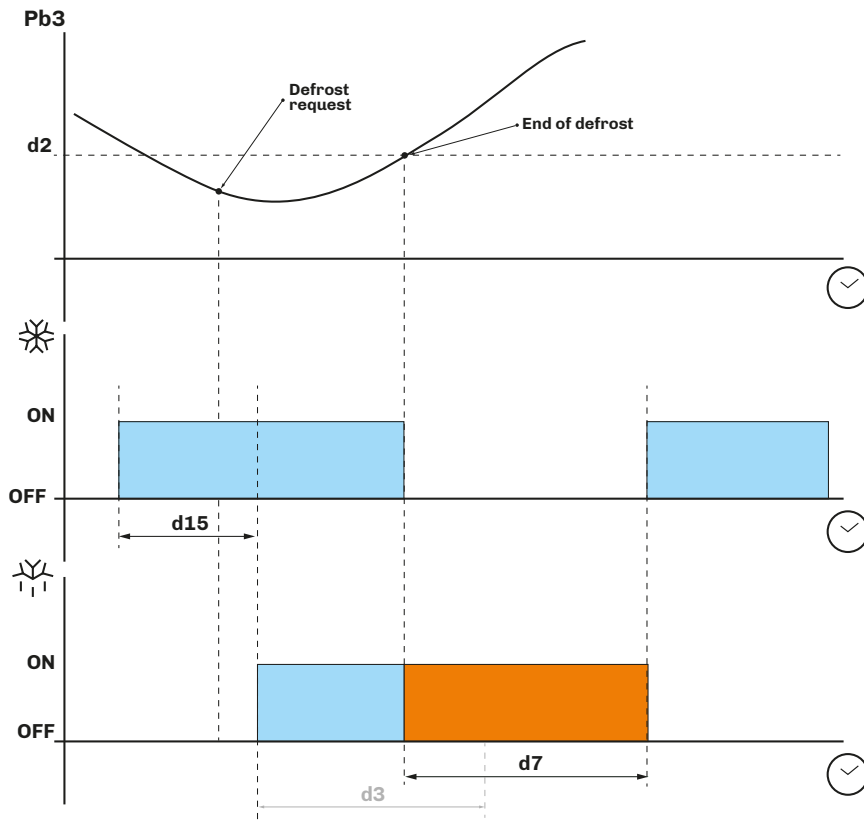

Fig. 18. Defrost with cycle reversed - End of defrost due to temperature

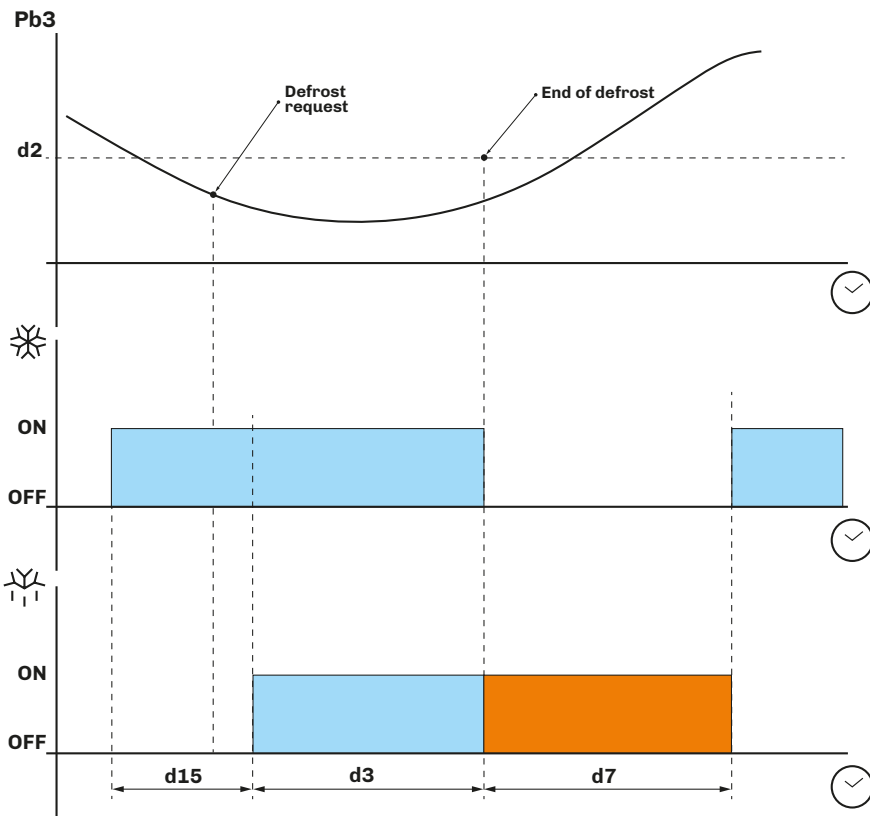

Fig. 19. Defrost with cycle reversed - End of defrost due to maximum time

6.3.3 Defrost when compressor stops

Defrost when the compressor stops is obtained by setting **d1** = 2.

The defrost configuration parameters with cycle reversed are:

Par.	Description	MU	Range
d0	Defrost interval.	h	0...99
d1	Type of defrost. 0 = Electrical heaters; 1 = Cycle reversed (hot gas); 2 = When compressor stops.	---	0...3
d3	Defrost duration.	min	0...99
d7	Evaporator dripping time after defrost.	min	0...15

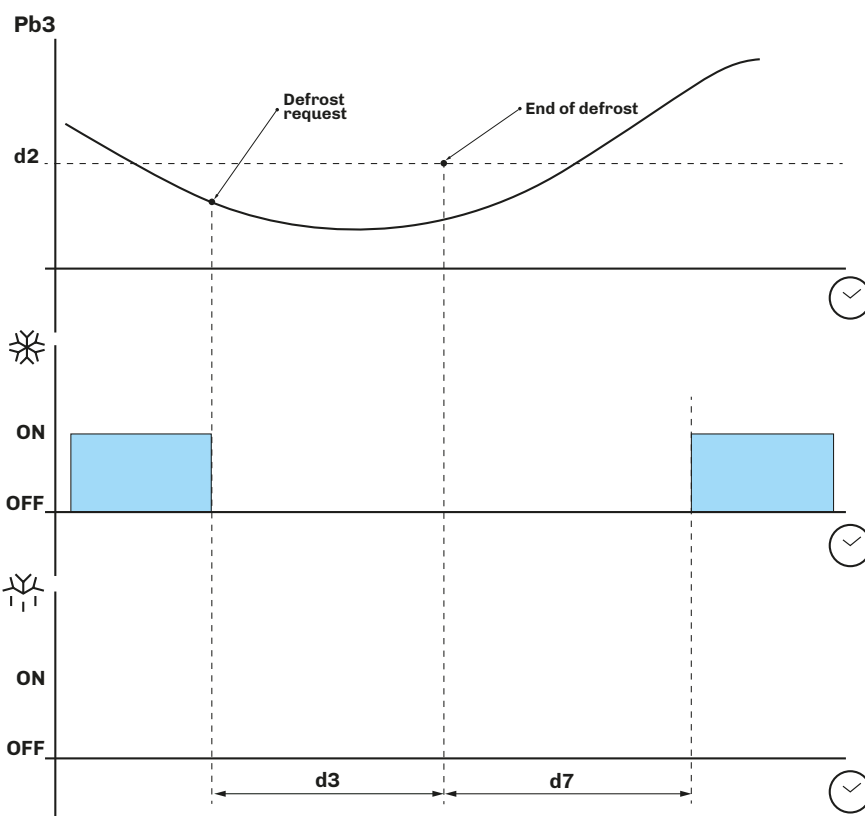

Fig. 20. Defrost when compressor stops - End of defrost due to maximum time

7. REGULATORS

7.1 HEATING/COOLING TEMPERATURE

The temperature regulation configuration parameters are:

Par.	Description	MU	Range
r0	Cooling regulation differential; temperature to be added to setpoint 1 (setpoint 1 + r0)	°C/°F	0.1...25.0
r1	Minimum value attributable to setpoint 1.	°C/°F	-30.0...r2
r2	Maximum value attributable to setpoint 1.	°C/°F	r1...99.0
r12	Heating regulation differential; temperature to be subtracted from setpoint 1 (setpoint 1 - r12)	°C/°F	-25.0...-0.1

7.1.1 Operation

The controller manages the temperature according to the type of request (heating/cooling).

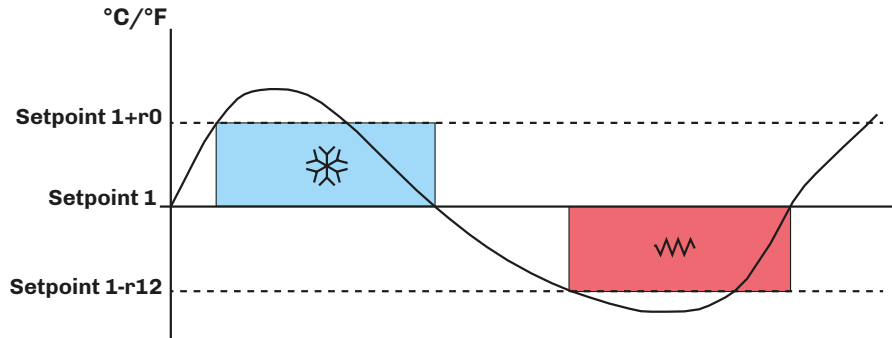

Fig. 21. Operation of temperature regulator

Cooling

If the controller receives a cooling request:

- Cooling output (Compressor) between **setpoint 1** and **setpoint 1 + r0**.

When the temperature read by Pb1 reaches the value of **setpoint 1 + r0**, the controller activates the compressor output to cool until the temperature goes below the threshold set by **setpoint 1**.

Heating

If the controller receives a heating request:

- Heating output (Heaters) between **setpoint 1** and **setpoint 1 - R12**.

When the temperature read by Pb1 reaches the value of **setpoint 1 - R12**, the controller activates the heater output to produce heat until the temperature goes above the threshold set by **setpoint 1**.

7.2 HEATING/COOLING TEMPERATURE IN THE NEUTRAL ZONE

The temperature regulation configuration parameters in the neutral zone are:

Par.	Description	MU	Range
r0	Cooling regulation differential; temperature to be added to setpoint 1 (setpoint 1 + r0)	°C/°F	0.1...25.0
r1	Minimum value attributable to setpoint 1.	°C/°F	-30.0...r2
r2	Maximum value attributable to setpoint 1.	°C/°F	r1...99.0
r11	Neutral zone value to add to differential. With r11 >0 the value is active for both heat (r11) and cooling regulation (r0), with r11 <0 for heat regulation only (r12).	°C/°F	0.0...10.0
r12	Heat regulation differential; temperature to be subtracted from setpoint 1 (setpoint 1 - r12)	°C/°F	-25.0...-0.1

7.2.1 Operation

Regulation in the neutral zone is activated if **r11** ≠ 0 (if **r11** < 0, the neutral zone is activated with a heating request).

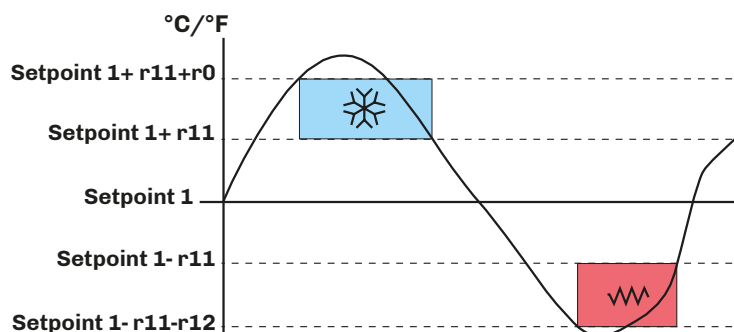

Fig. 22. Operation of temperature regulator in the neutral zone

Cooling

If the controller receives a cooling request:

- Cooling output (Compressor) between **setpoint 1 + r11 + r0** and **setpoint 1 + r11**.

When the temperature read by Pb1 reaches the value of **setpoint 1 + r11 + r0**, the controller activates the compressor output until the temperature goes below the threshold set by **setpoint 1 + r11**.

Heating

If the controller receives a heating request:

- Heating output (Heaters) between **setpoint 1 - r11 - r12** and **setpoint 1 - r11**.

When the temperature read by Pb1 reaches the value of **setpoint 1 - r11 - r12**, the controller activates the heater output to produce heat until the temperature goes above the threshold set by **setpoint 1 - r11**.

7.3 TEMPERATURE AND DEHUMIDIFICATION WITH THE COMPRESSOR

The temperature regulation configuration parameters are:

Par.	Description	MU	Range
rd4	Dehumidification with compressor only or with compressor and heaters (heating). 0 = Disabled; 1 = Compressor; 2 = Compressor and heating.	---	0...2

7.3.1 Operation

- If **rd4** = 1, the dehumidification function with the compressor is activated.
- If **rd4** = 2, the dehumidification function with the compressor and heating outputs is activated.

7.3.2 Temperature priority over dehumidification

If **rd4** = 1, 2 the dehumidification function is activated and works with the compressor and heater outputs. This makes it necessary to set the controller's regulation priority.

The parameter for configuring regulation priority is:

Par.	Description	MU	Range
r14	Temperature priority over dehumidification with the compressor and heater outputs. 0 = No priority, the regulations are independent; 1 = If temperature drifts up, this has priority over dehumidification until temperature is restored; 2 = If temperature drifts up and down, this has priority over dehumidification until temperature is restored; 3 = If temperature drifts down, this has priority over dehumidification until temperature is restored.	---	0...3

7.4 HUMIDITY

The humidity regulation configuration parameters are:

Par.	Description	MU	Range
rd0	Dehumidification regulation differential to be added to setpoint 2 (setpoint 2 + rd0).	%	1...25
h1	Minimum value attributable to setpoint 2.	%	0... h2
h2	Maximum value attributable to setpoint 2.	%	h1 ...100
rh0	Humidification regulation differential to be added to setpoint 2 (setpoint 2 + rh0).	%	-25...-1

7.4.1 Operation

The controller manages humidification and dehumidification requests by setting parameters **rd0** and **rh0**.

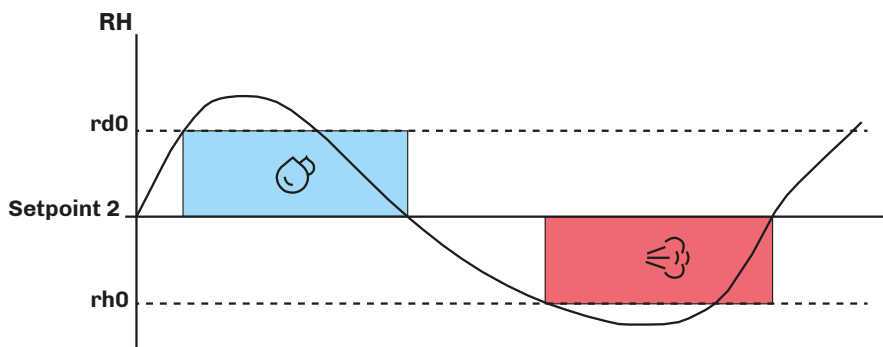

Fig. 23. Operation of temperature regulator

7.5 HUMIDITY IN THE NEUTRAL ZONE

The humidity regulation configuration parameters in the neutral zone are:

Par.	Description	MU	Range
rd0	Dehumidification regulation differential to be added to setpoint 2 (setpoint 2 + rd0 + rd1).	%	1...25
h1	Minimum value attributable to setpoint 2.	%	0... h2
h2	Maximum value attributable to setpoint 2.	%	h1 ...100
rh0	Humidification regulation differential to be added to setpoint 2 (setpoint 2 + rh0 + rh1).	%	-25...-1
rd1	Dehumidification neutral zone setpoint 2 - rd1 .	%	0...10
rh1	Humidification neutral zone setpoint 2 - rh1 .	%	0...10

7.5.1 Operation

Regulation in the neutral zone is active:

- For humidification, if **rh1** ≠ 0;
- For dehumidification, if **rd1** ≠ 0.

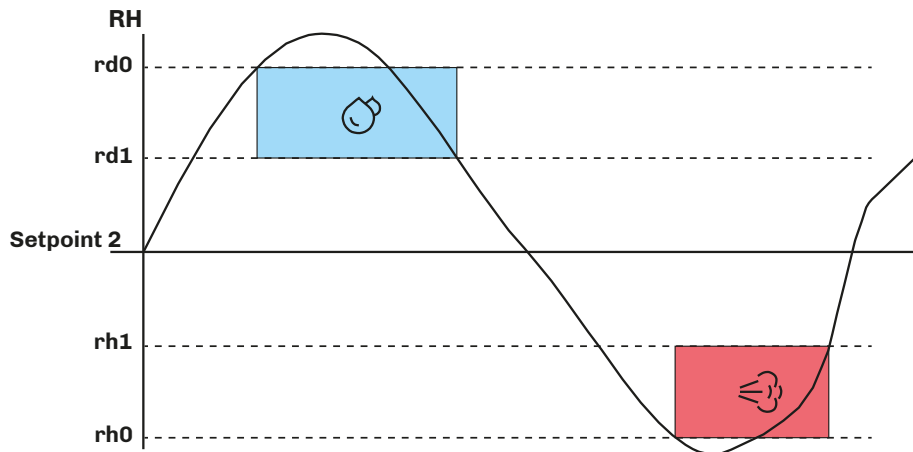

Fig. 24. Operation of temperature regulator

7.6 COMPRESSOR

The compressor regulator operates when at least one relay output is configured as the compressor **uc1...uc6** = 4.

The switching on/off of the compressor is controlled by:

- Temperature read by probe Pb1;
- Configuration of the heat regulations;
- Defrost and dripping.

Conditions for activation

The compressor is activated if the following conditions are met:

- The controller is on (regulation is blocked when the controller is in stand-by);
- Probe Pb1 is working;
- Compressor activation delay **C0** from switch-on is terminated;
- Compressor switch-on delay **C2** between 2 consecutive activations;
- If **d1** = 0, 2, defrost and dripping must be terminated.

If a delay **C0** or **C2** is set and there is a request for compressor activation, the controller waits for the delay to end before activating the compressor. During the wait, the  icon flashes until the compressor is activated, after which it stays on.

The compressor regulation configuration parameters are:

Par.	Description	MU	Range
C0	Compressor ON delay from power-on.	min	0...240
C2	Minimum compressor OFF time.	min	0...240
C3	Minimum compressor ON time.	s	0...240
C4	Compressor OFF time in cabinet probe alarm.	min	0...240
C5	Compressor ON time in cabinet probe alarm.	min	0...240
C6	Condensation temperature above which the condenser overheat alarm sounds.	°C/°F	0...199
C7	Condenser temperature above which the compressor locked alarm sounds, once C8 time has elapsed.	°C/°F	0...199
C8	Delay in activation of compressor locked alarm due to threshold C7 being exceeded.	min	0...15

Par.	Description	MU	Range
C10	Compressor days for maintenance.	days	0...990
C11	Compressor 2 switch-on delay from compressor 1 switch-on.	s	0...240

7.6.1 Operating diagrams

Normal compressor operation

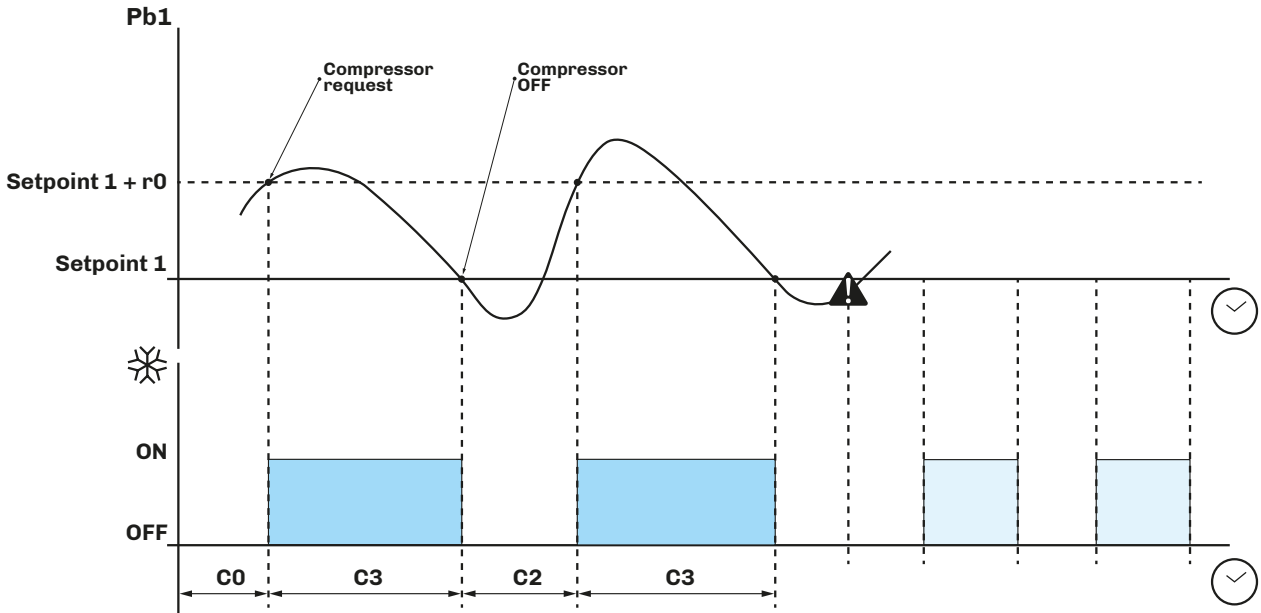

Fig. 25. Normal compressor operation

Compressor operation with alarm probe

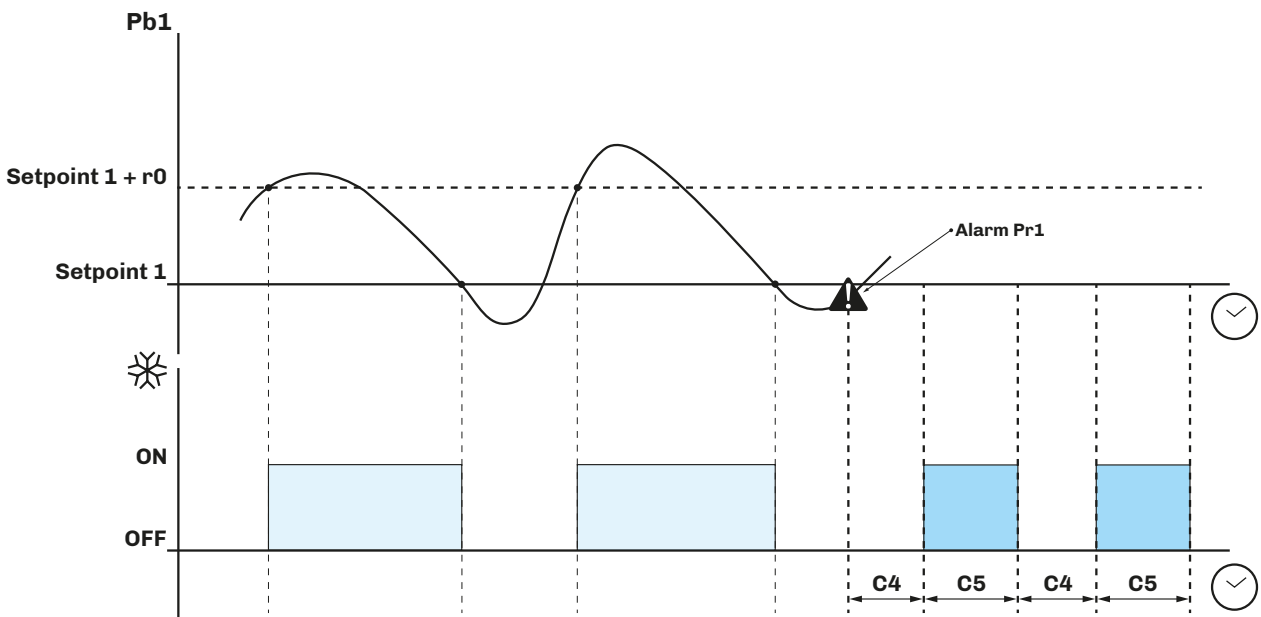

Fig. 26. Operation with compressor alarm probe

7.7 DOUBLE COMPRESSOR

If one of the digital outputs is set as compressor 2, **uc1...uc6** = 10, the controller manages two compressors.

Activating compressor 2

Compressor 2 is activated after a delay **C11** from compressor 1 switch-off.

If active, compressor 2 uses the:

- Setpoints;
- Differentials;
- Delays and
- Protections

set for compressor 1.

7.7.1 Operating Diagram

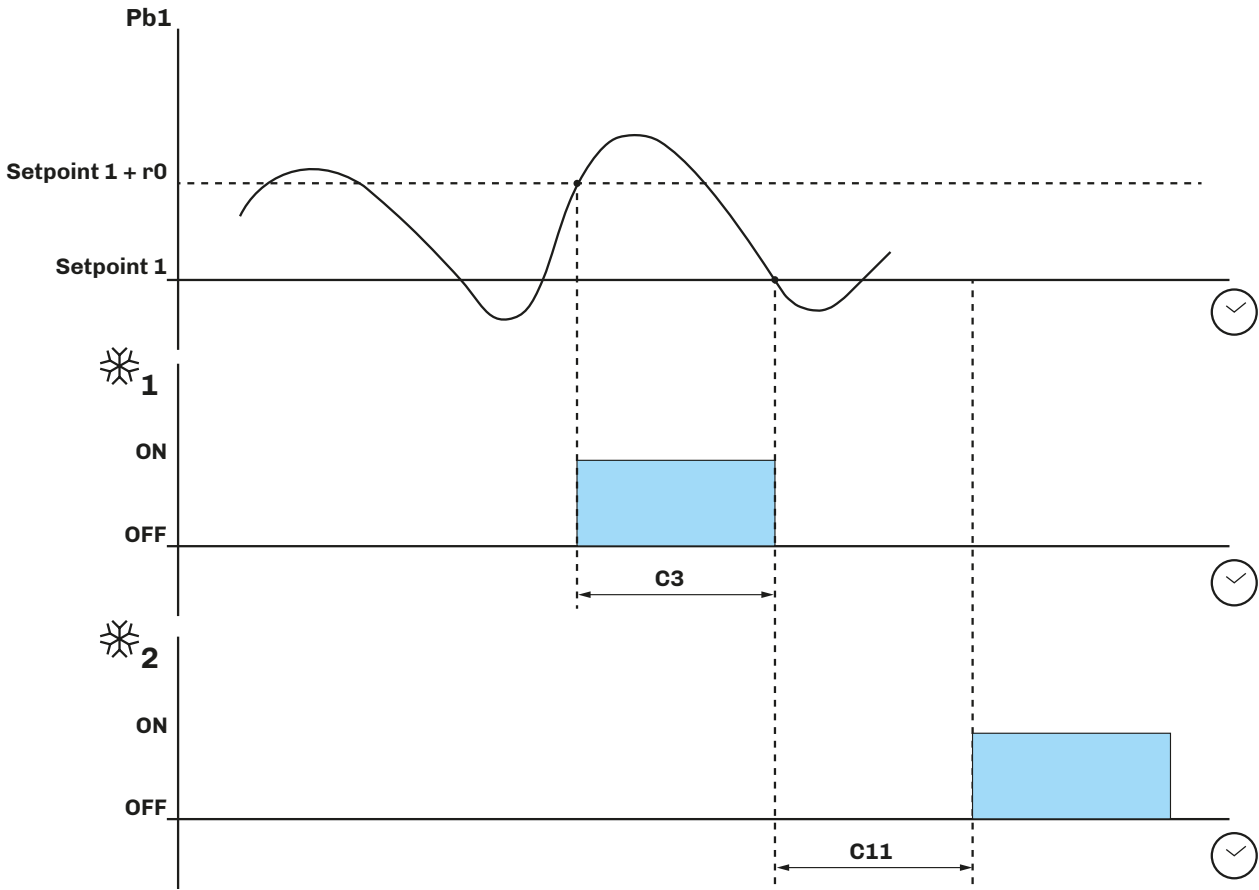

Fig. 27. Normal compressor 2 operation

7.8 EVAPORATOR FANS

The evaporator fan regulator is activated in the following conditions:

- The delay **F3** has elapsed at the end of dripping;
- The temperature of the evaporator probe Pb3 is higher than the threshold **F1** (if **F0** = 3, 4);
- The fans are not deactivated during defrost **F2** = 0;
- There is no dripping active **d7**.

7.8.1 Regulator operation

The evaporator fan regulator may be activated following a request from another regulator as follows:

- Compressor request, to encourage production and diffusion of cool air (heat regulation function);
- Defrost request, to control/limit the diffusion of hot air;
- Humidification/dehumidification request, to spread or limit the diffusion of humidity.

7.8.2 Operating mode

The evaporator fans operate according to parameter **F0**:

Par.	Description	MU	Range
F0	Evaporator fan mode in normal operating mode. With F0 = 0 it is possible to manage cycles by setting F11 , F12 , rd2 , rd3 , rh2 , rh3 . 0 = In cycles; 1 = Always ON; 2 = ON according to loads; 3 = Thermostat controlled (F1 relative to temperature control); 4 = ON according to loads and thermostat controlled (F1 relative to temperature control).	---	0...4

Evaporator fan cycles with **F11** > 0

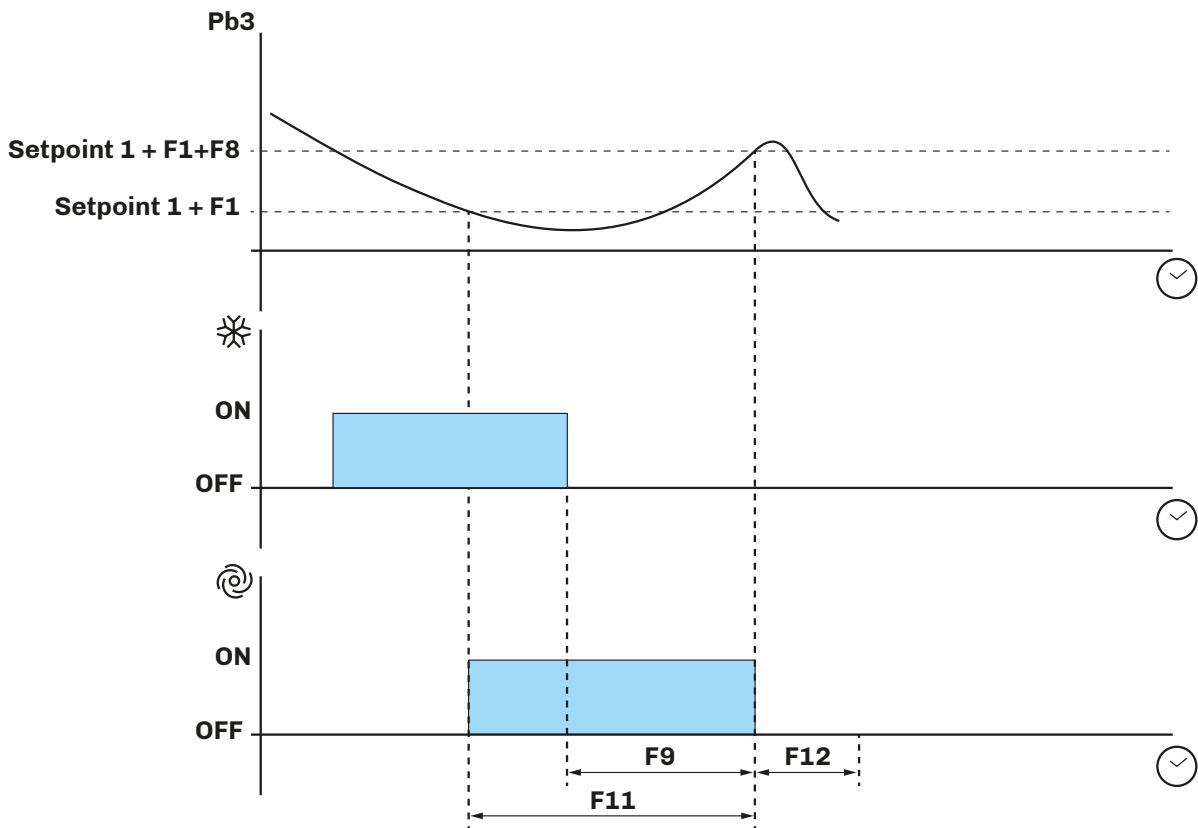

Fig. 28. Operation of evaporator fans with **F11** > 0

7.8.3 Operation during defrost

Operation of the evaporator fans during defrost depends on **F2**.

Par.	Description	MU	Range
F2	Evaporator fan mode during defrost. 0 = OFF; 1 = ON; 2 = According to F0 .	---	0...2

7.8.4 Fan operation during dripping

During dripping, the evaporator fans stay off for the time set by **d7**. A further delay of **F3** may be set when the evaporator fans are activated after dripping. In this case, the fans are activated after **F3** has elapsed.

7.9 CONDENSER FANS

7.9.1 Operation

The condenser fans are activated in the following conditions:

- The digital output **uc1...uc6** = 6 (configured as condenser fans);
- If **Pb3** ≠ 1, the condenser fans are activated in parallel with the compressor;
- If **Fc3** = 0, the fans are activated at the threshold **Fc1+Fc2** and switch off at the threshold **Fc1** (working in parallel with the compressor and thermostat controlled);
- If **Fc3** > 0, the fans are activated at the threshold **Fc1+Fc2** and switch off at the threshold **Fc1** (working independently of the compressor and thermostat controlled);
- During hot gas defrost, they are activated if the temperature **Pb3** goes above the alarm threshold **C6**.

7.10 ENERGY SAVING

7.10.1 Operation

Energy saving can be activated:

- By digital input **iC1** = 1
- By key (see "**5.4.4 Functions that can be activated by key**" on page 21);
- If the door stays open > **i10**: energy saving is then activated for the time **HE2**;
- By the RTC clock, activating the energy saving function every day at the time **H01** for a time of **H02**.

With energy saving active:

- **Setpoint 1** is replaced by **setpoint 1 + r4**.

The energy saving configuration parameters are:

Par.	Description	MU	Range
r4	Setpoint offset in energy saving added to setpoint value.	°C/°F	0.0...99.0
HE2	Manual energy saving duration.	min	0...999
H01	Daily start time of energy saving temperature.	h	0...23
H02	Duration of daily energy saving.	h	0...24

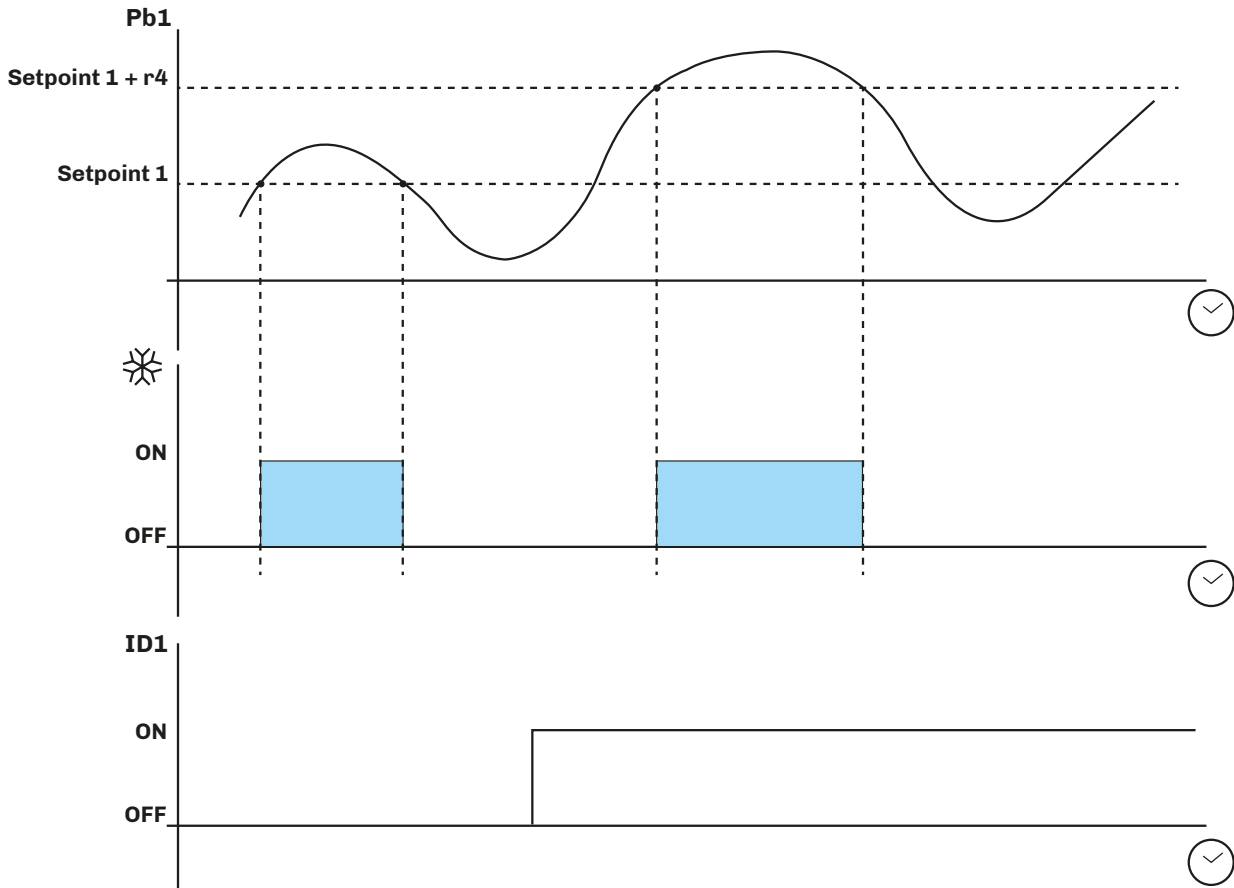

Fig. 29. Operation in energy saving function

8. FUNCTIONS

8.1 SANITATION (EVJ 526 ONLY)

The sanitation cycle is available in model **EVJ 526** only and offers:

- Food sanitation using UV-C lamps;
- Cabinet sterilisation using ozone generators.

Sanitation using UV-C lamps helps eliminate viruses and bacteria from food without contaminating it.

Sterilisation using ozone generators helps eliminate and prevent the proliferation of viruses and bacteria in cold rooms, keeping them clean and healthy.

This function is activated by keys, see "**5.4.4 Functions that can be activated by key" on page 21**" and can be used when at least one relay output is configured as Sanitation **uc1...uc6 = 16**.

During sanitation, the  icon stays on, whereas it flashes during the interval between two sanitation cycles.

The sanitation configuration parameters are:

Par.	Description	MU	Range
u10	Sanitation duration.	min	0...99
u11	Interval between 2 sanitation cycles.	min	0...999
u12	Evaporator fan status during sanitation. 0 = Independent; 1 = Active.	---	0/1
u13	Sanitation in stand-by. 0 = UV lamps; 1 = Ozone generator in stand-by, temperature/humidity regulation off; 2 = Ozone generator in stand-by and operating, temperature/humidity regulation suspended.	---	0...2

8.2 AGING (EVJ 536 ONLY)

The aging function is only available with the **EVJ 536** models.

EVJ 536 has 6 factory set programmes.

Each of the 6 programmes has 3 processes, in this order:

- Dripping;
- Drying in 6 phases;
- Aging.

For each of these 3 processes, it is possible to set:

- Duration (if set to 0 h, it moves on to the next phase);
- Temperature setpoint (**SET 1**);
- Humidity setpoint (**SET 2**);
- Enable/disable reduced ventilation and;
- Enable/disable the pause-work between the end of a phase and the beginning of the next one.

Default settings of the 6 pre-set programmes

Each of the 6 pre-set programmes has the following default map:

	Dripping	Drying						Aging
		1	2	3	4	5	6	
Duration (*)	10 h	15 h	24 h	24 h	24 h	24 h	24 h	1 d
Set 1	20 °C	19 °C	19 °C	18 °C	17 °C	16 °C	15 °C	14 °C
Set 2	0 %	75 %	68 %	65 %	68 %	72 %	76 %	82 %
Reduced ventilation	No	No	No	No	No	No	No	No
Resting	No	Yes	Yes	Yes	Yes	Yes	Yes	No
Defrost	Manual	Manual	Manual	Manual	Manual	Manual	Manual	Manual
Air Change	Manual	Manual	Manual	Manual	Manual	Manual	Manual	Manual

8.3 COPYING THE PARAMETERS

8.3.1 Introduction

EVJKEY can be connected to the TTL serial port to upload and download the map of the parameters.

For further information, consult the instruction sheet p/n 104JKEYA304.

8.3.2 Uploading the parameters from the controller to EVJKEY

With **EVJKEY** connected to the TTL serial port:

1. Set dip switches 1, 2 and 3 to OFF;
2. Plug the controller into the mains;
3. Recognition of the EVJKEY will automatically start up (the OK and ERROR LEDs come on and stay on);
4. When recognition is complete, the data are automatically uploaded.

This may take a couple of seconds.

If the upload is successful, the OK LED stays on while the ERROR LED goes off. If it has not been successful, the OK LED goes off while the ERROR LED stays on; repeat the procedure.

8.3.3 Downloading the parameters from EVJKEY to the controller

With **EVJKEY** connected to the TTL serial port:

1. Set dip switches 1, 2 and 3 to ON;
2. Plug the controller into the mains;
3. Recognition of the EVJKEY will automatically start up (the OK and ERROR LEDs come on and stay on);
4. When recognition is complete, the data are automatically uploaded.

This may take a couple of seconds.

If the download is successful, the OK LED stays on while the ERROR LED goes off. If it has not been successful, the OK LED goes off while the ERROR LED stays on; repeat the procedure.

9. PARAMETERS

Description of columns in the Table of Parameters

- **Par.:** List of configurable device parameters;
- **Description:** Indicates parameter operation and any possible selections;
- **MU:** Measurement unit relating to the parameter;
- **Range:** Describes the interval of values that the parameter can assume. This can be correlated with other instrument parameters (indicated with the parameter code).
NOTE: if the actual value is outside the permitted limits for that parameter (for example, because other parameters defining the aforementioned limits have been altered), the value of the violated limit is displayed instead of the actual value;
- **Default:** Indicates the pre-set factory configuration;
- **PW:** Indicates the access level for the parameter.

9.1 TABLE OF CONFIGURATION PARAMETERS

Par.	Description	MU	Range	Default models			PW
				506	526	536	
ANALOGUE INPUTS Group							
CA1	Pb1 probe offset.	°C/°F	-25.0...25.0	0.0	0.0	0.0	1
CA2	Pb2 probe offset.	°C/°F	-25.0...25.0	0.0	0.0	0.0	1
CA3	Pb3 probe offset.	°C/°F	-25.0...25.0	0.0	0.0	0.0	2
P0	Type of probe. 0 = PTC + EVHTP500; 1 = NTC + EVHTP500; 2 = PTC + EVHTP520; 3 = NTC + EVHTP520.	---	0/1	1	1	1	2
P1	Enable decimal point in °C. 0 = No; 1 = Yes.	---	0/1	1	1	1	2
P2	Temperature measurement unit (if the value is changed, the temperature parameter limits must be reset manually). 0 = °C; 1 = °F.	---	0/1	0	0	0	2
Pr3	Probe Pb3 configuration. 0 = Digital input ID3; 1 = Condenser probe; 2 = Needle probe (display only); 3 = External air probe (display only). 4 = Auxiliary probe; 5 = Defrost 2 probe.	---	0...5	5	5	5	2
P5	Large display 1 value. 0 = No information displayed (display off); 1 = Analogue input 1; 2 = Analogue input 2; 3 = Analogue input 3; 4 = Setpoint 1 (Temperature); 5 = Setpoint 2 (Humidity).	---	0...5	1	1	1	2
P6	Small display 2 value. Same as P5.	---	0...5	2	2	2	2
P8	Refresh time display 1. Increase or decrease by 1 digit for interval selected.	s	0...250	5	5	5	2
P9	Refresh time display 2. Increase or decrease by 1 digit for interval selected.	s	0...250	5	5	5	2
P31	Enable setpoint change of programme in progress and times during active cycle. 0 = No; 1 = Yes.	---	0/1			1	2
P32	If P31 = 1 save changes to setpoints in the programme too. Timer variations are excluded. 0 = No; 1 = Yes.	---	0/1			0	2
TEMPERATURE REGULATION Group							
r0	Cooling mode setpoint differential.	°C/°F	0.1...25.0	2.0	2.0	2.0	1
r1	Minimum setpoint.	°C/°F	-30.0...r2	0.0	0.0	0.0	2
r2	Maximum setpoint.	°C/°F	r1...99.0	50.0	50.0	50.0	2
r4	Setpoint offset in energy saving added to setpoint value.	°C/°F	0.0...99.0	0.0	0.0	0.0	2
r5	Disable humidity regulation in OverTemp function. 0 = No; 1 = Yes.	---	0/1	0	0		2
r6	Threshold relative to Setpoint 1 temperature in OverTemp function.	°C/°F	-40.0...99.0	0.0	0.0		2

Par.	Description	MU	Range	Default models			PW
				506	526	536	
r7	Duration of OverTemp function.	min	0...240	0	0		2
r11	Neutral zone value to add to differential.	°C/°F	-10.0...10.0	0.0	0.0	0.0	2
r12	Heating differential.	°C/°F	-25.0...-0.1	-2.0	-2.0	-2.0	1
r13	Heating output duty cycle. 60 = Always ON.	s	0...60	60	60	60	2
r14	Temperature priority 0 = No priority, the regulations are independent; 1 = Heat regulation has priority over dehumidification until temperature is restored; 2 = Heat and cooling regulation has priority over dehumidification until temperature is restored; 3 = Cooling regulation has priority over dehumidification until temperature is restored.	---	0...3	2	2	2	2
HUMIDIFICATION/DEHUMIDIFICATION Group							
h1	Minimum setpoint 2 humidity	%	0...h2	10	10	10	2
h2	Maximum setpoint 2 humidity	%	h1...100	95	95	95	2
h4	Extra humidity setpoint activated by AUX key. The value h4 replaces Setpoint 2 for the time h5 .	%	0...100	0	0		2
h5	Extra humidity setpoint duration h4 . 0 = function disabled.	min	0...240	0	0		2
rd0	Dehumidification differential.	%	1...25	3	3	3	1
rd1	Dehumidification neutral zone.	%	0...10	0	0	0	2
rd2	Fan ON time during dehumidification with F0 = 0 . 0 = fans off.	s	0...240	60	60	60	2
rd3	Fan OFF time during dehumidification with F0 = 0 . If rd3 = 0 and rd2 ≠ 0 fans are always on.	s	0...240	0	0	0	2
rd4	Dehumidification with compressor or with compressor and heating. 0 = Disabled; 1 = Compressor; 2 = Compressor and heating.	---	0...3	1	1	1	2
rd5	Heat and dehumidification with defrost output. 0 = No; 1 = Yes.	---	0/1	0	0	0	2
rh0	Humidification differential.	%	-25...-1	-3	-3	-3	1
rh1	Humidification neutral zone.	%	0...10	0	0	0	2
rh2	Humidification output on time (or fans if no RH output is configured). With rh2 = 0 fans off.	s	0...240	60	60	60	2
rh3	Humidification output off time (or fans if no RH output is configured). With rh3 = 0 and rh2 > 0 , fans are always on.	s	0...240	0	0	0	2
COMPRESSOR Group							
C0	Compressor ON delay from power-on.	min	0...240	0	0	0	2
C2	Minimum compressor OFF time.	min	0...240	3	3	3	2
C3	Minimum compressor ON time.	s	0...240	0	0	0	2
C4	Compressor OFF time in cabinet probe alarm.	min	0...240	10	10	10	2
C5	Compressor ON time in cabinet probe alarm.	min	0...240	10	10	10	2
C6	Condensation temperature above which the condenser overheat alarm sounds.	°C/°F	0...199	80.0	80.0	80.0	2
C7	Condenser temperature above which the compressor locked alarm sounds, once C8 time has elapsed.	°C/°F	0...199	90.0	90.0	90.0	2
C8	Delay in activation of compressor locked alarm due to threshold C7 being exceeded.	min	0...15	0	0	0	2
C10	Compressor days for maintenance.	day	0...990	0	0	0	2
C11	Compressor 2 switch-on delay from compressor 1 switch-on.	s	0...240	10	10	10	2
DEFROST Group							
d0	Defrost interval.	h	0...99	8	8	8	1
d1	Type of defrost. 0 = Electrical heaters; 1 = Cycle reversed (hot gas); 2 = When compressor stops.	---	0...3	0	0	0	2
d2	Evaporator temperature above which defrost with evaporator probe terminates (Pr3 = 5).	°C/°F	-99.0...99.0	8.0	8.0	8.0	1

Par.	Description	MU	Range	Default models			PW
				506	526	536	
d3	Defrost duration.	min	0...99	30	30	30	1
d4	Enable defrost when device is switched on. 0 = No; 1 = Yes, activate defrost at switch-on; 2 = Activate defrost after over-cooling; 3 = Activate defrost at switch-on and after over-cooling.	---	0...3	0	0	0	2
d5	Time between switching the device on and starting defrost.	min	0...99	0	0	0	2
d6	Value displayed during defrost. 0 = Regulation; 1 = Display locked; 2 = Unused.	---	0...2	1	1	1	2
d7	Evaporator dripping time after defrost.	min	0...15	0	0	0	2
d11	Enable defrost terminated warning due to maximum duration (code dFd). 0 = No; 1 = Yes.	---	0/1	0	0	0	2
d13	Defrost during pause-work (resting). 0 = No; 1 = Yes.	---	0/1			0	2
d15	Compressor ON time before hot gas defrost.	min	0...99	0	0	0	2
ALARM Group							
A1	Low temperature alarm threshold.	°C/°F	-99.0...99.0	0.0	0.0	0.0	2
A2	Type of low temperature alarm. 0 = Disabled; 1 = Relative to SET; 2 = Absolute.	---	0...2	2	2	2	2
A4	High temperature alarm threshold.	°C/°F	-99.0...99.0	50.0	50.0	50.0	2
A5	Type of high temperature alarm. 0 = Disabled; 1 = Relative to SET; 2 = Absolute.	---	0...2	2	2	2	2
A6	Delay in activation of temperature and humidity alarms due to threshold exceeded when device is switched on.	min	0...240	120	120	120	2
A7	Minimum and maximum temperature alarm delay.	min	0...240	15	15	15	2
A8	Delay in activation of alarm due to threshold exceeded after defrost.	min	0...240	15	15	15	2
A9	Delay in activation of alarm due to threshold exceeded after door closed.	min	0...240	15	15	15	2
A10	Duration of power failure to record alarm.	min	0...240	15	15	15	2
A11	Hysteresis referring to A1 and A4 to determine alarm reset threshold.	°C/°F	0.1...15	1.0	1.0	1.0	2
AH1	Alarm relative to low humidity SET2.	%	0...100	50	50	50	2
AH4	Alarm relative to high humidity SET2.	%	0...100	50	50	50	2
AH7	Humidity and probe saturation alarm delay	min	0...240	30	30	30	2
EVAPORATOR/CONDENSER FANS Group							
F0	Evaporator fan mode in normal operating mode. With F0 = 0 it is possible to manage cycles by setting F11, F12, rd2, rd3, rh2, rh3. 0 = In cycles; 1 = Always ON; 2 = ON according to loads; 3 = Thermostat controlled (F1 relative to temperature control); 4 = ON according to loads and thermostat controlled (F1 relative to temperature control).	---	0...4	1	1	1	2
F1	Evaporator fan regulation threshold with F0 = 3, 4 (relative to the setpoint).	°C/°F	-99.0...99.0	99.0	99.0	99.0	2
F2	Evaporator fan mode during defrost. 0 = OFF; 1 = ON; 2 = According to F0.	---	0...2	0	0	0	2
F3	Maximum time evaporator fans off after dripping.	min	0...15	0	0	0	2
F7	Threshold in relation to setpoint to start fans up again after defrost.	°C/°F	-99.0...99.0	99.0	99.0	99.0	2
F8	Evaporator setpoint differential.	°C/°F	0.1...15.0	2.0	2.0	2.0	2
F9	Evaporator fan switch-off delay from compressor switch-off	s	0...240	5	5	5	2
F11	Fans ON time when regulation is not in progress with F0 = 0. F11 = 0 fans are off.	s	0...240	60	60	60	2
F12	Fans OFF time when regulation is not in progress with F0 = 0. F12 = 0 and F11 > 0 fans are always on.	s	0...240	0	0	0	2
F30	Evaporator fan status during air change. 0 = Off; 1 = On.	---	0/1			0	2
F31	Air change 1 activation time. "----" = Disabled.	h	----, 0...24			24	2
F32	Air change 2 activation time. "----" = Disabled.	h	----, 0...24			24	2

Par.	Description	MU	Range	Default models			PW
				506	526	536	
F33	Air change 3 activation time. "----" = Disabled.	h	----, 0...24			24	2
F34	Air change 4 activation time. "----" = Disabled.	h	----, 0...24			24	2
F35	Air change 5 activation time. "----" = Disabled.	h	----, 0...24			24	2
F36	Air change 6 activation time. "----" = Disabled.	h	----, 0...24			24	2
Fc1	Condenser fans OFF threshold.	°C/°F	0.0...99.0	25.0	25.0	25.0	2
Fc2	Condenser fans ON differential.	°C/°F	0.1...15.0	5.0	5.0	5.0	2
Fc3	Condenser fans switch-off delay.	s	0...240	5	5	5	2
DIGITAL INPUT PROPERTIES Group							
i1	Display locked with door open and after closing.	min	0...240	0	0	0	2
i2	Delay in alarm signal from door open. -1 = Disabled.	min	-1...120	15	15	15	2
i3	Maximum time for inhibiting regulation with door open according to configuration ic1 = 7, 8, 9. -1 = Disabled.	min	-1...120	15	15	15	2
i5	Multi-purpose input alarm delay.	min	0...120	0	0	0	2
i6	High pressure events counting interval Pr3 = 0 and ic3 = 1. From the first event, i8 events are counted for manual reset.	min	0...120	60	60	60	2
i7	Thermal switch events counting interval ic1 = 5. From the first event, i8 events are counted for manual reset.	min	0...120	60	60	60	2
i8	Digital input event counting for pressure switch and/or thermal switch alarm. 0 = Always automatic; 1 = Always manual.	---	0...15	1	1	1	2
AUXILIARY OUTPUT Group							
u5	Door heaters activation threshold.	°C/°F	-99.0...99.0		0		2
u6	Auxiliary output configuration. Use the AUX key for manual control. 0 = Heating; 1 = Cold; 2 = Manual.	---	0...2	0	0	0	2
u7	Auxiliary setpoint if u6 = 0, 1.	°C/°F	-99.0...99.0	0.0	0.0	0.0	2
u8	Differential for auxiliary setpoint u7.	°C/°F	0.1...15.0	1.0	1.0	1.0	2
u10	Sanitation duration.	min	0...99		0		2
u11	Interval between 2 sanitation cycles.	min	0...999		0		2
u12	Evaporator fan status during sanitation. 0 = Independent; 1 = Active.	---	0/1		0		2
u13	Sanitation in stand-by. 0 = UV lamps; 1 = Ozone generator in stand-by, temperature/humidity regulation off; 2 = Ozone generator in stand-by and operating, temperature/humidity regulation suspended.	---	0...2		0		2
DIGITAL INPUT CONFIGURATION Group							
ic1	Digital input 1 function. 0 = Disabled; 1 = Energy saving; 2 = Multi-purpose alarm; 3 = Reserved; 4 = Stand-by; 5 = Thermal switch 1; 6 = Thermal switch 2; 7 = Compressor and fans OFF, light ON; 8 = Fans OFF, light ON. 9 = Light ON; 10 = Compressor and fans OFF; 11 = Fans OFF.	---	0...11	7	7	7	2
ip1	Multi-purpose input 1 activation (polarity). 0 = Contact closed (NC); 1 = Contact open (NO).	---	0/1	0	0	0	2

Par.	Description	MU	Range	Default models			PW
				506	526	536	
iC3	Digital input 3 function. 0 = Disabled; 1 = High pressure switch.	---	0/1	0	0	0	2
iP3	Multi-purpose input 3 activation (polarity). 0 = Contact closed (NC); 1 = Contact open (NO).	---	0/1	0	0	0	2
DIGITAL OUTPUT CONFIGURATION Group							
uc1	Configure relay output out1 . 0 = Disabled; 1 = Humidity (RH); 2 = Dehumidification (dRH); 3 = Alarm; 4 = Compressor 1; 5 = Heating; 6 = Condenser fan; 7 = ON/OFF; 8 = Air change; 9 = Light; 10 = Compressor 2; 11 = Evaporator fans; 12 = Defrost; 13 = Door frame (EVJ 526 only); 14 = Evaporator fans 2 (EVJ 526/ EVJ 536 only); 15 = Auxiliary; 16 = Sanitation (EVJ 526 only).	---	0...16	4	4	4	2
uc2	Configure relay output out2 . Same as uc1 .	---	0...16	5	5	5	2
uc3	Configure relay output out3 . Same as uc1 .	---	0...16	9	9	9	2
uc4	Configure relay output out4 . Same as uc1 .	---	0...16	1	1	1	2
uc5	Configure relay output Out5 . Same as uc1 .	---	0...16	11	11	11	2
uc6	Configure relay output out6 . Same as uc1 .	---	0...16	12	12	12	2
KEY CONFIGURATION Group							
POF	Enable stand-by key (ON/OFF). 0 = Disabled; 1 = Enabled.	---	0/1	1	1	1	2
PLi	Enable light key in stand-by. 0 = Disabled; 1 = Enabled.	---	0/1	1	1	1	1
PSr	Deactivate alarm output with silencing buzzer. 0 = Do not deactivate; 1 = Deactivate.	---	0/1	1	1	1	1
Pbu	Buzzer operation configuration. 0 = Buzzer deactivated; 1 = Alarm signal only; 2 = Alarm signal and keypad feedback.	---	0...2	2	2	2	2
SEn	Capacitive keypad threshold.		60...120	70	70	70	
PLo	Keypad inactivity time, after which it locks.	s	0...240	60	60	60	
PASSWORD Group							
PAS	Level 2 password to access parameters (installer).	---	-99... 999	-19	-19	-19	2
PS1	Level 1 password to access parameters (user).	---	-99... 999	1	1	1	2
PA1	EVlink/EVconnect user password (not entered on device).	---	-99... 999	426	426	426	2
PS2	EVlink/EVconnect password service.	---	-99... 999	824	824	824	2
CLOCK Group							
Hr0	Enable clock. 0 = Disabled; 1 = Enabled.	---	0/1	0	0	0	2
REMOTE COMMUNICATION Group							
BLE	Type of communication. 0 = Local (MODBUS); 1 = Remote (EVLINK) (Do not change parameters LA , Lb and LP).	---	0/1	1	1	1	2

Par.	Description	MU	Range	Default models			PW
				506	526	536	
rE0	Recording interval.	min	0...240	15	15	15	2
rE1	Value to record. 0 = No value to record; 1 = Only probe Pb1 value; 2 = Only probe Pb2 value; 3 = Only probe Pb3 value; 4 = Probe Pb1 and Pb2 value; 5 = Value of all the probes.	---	0...5	4	4	4	2
RTC DEFROST CONFIGURATION Group							
Hd1	Defrost 1 activation time. "----" = Disabled.	h	----, 0...23	----	----	----	2
Hd2	Defrost 2 activation time. "----" = Disabled.	h	----, 0...23	----	----	----	2
Hd3	Defrost 3 activation time. "----" = Disabled.	h	----, 0...23	----	----	----	2
Hd4	Defrost 4 activation time. "----" = Disabled.	h	----, 0...23	----	----	----	2
Hd5	Defrost 5 activation time. "----" = Disabled.	h	----, 0...23	----	----	----	2
Hd6	Defrost 6 activation time. "----" = Disabled.	h	----, 0...23	----	----	----	2
MODBUS CONFIGURATION Group							
LA	MODBUS protocol controller address.	---	0...247	247	247	247	2
Lb	MODBUS transmission speed (baud rate). 0 = 2400; 1 = 4800; 2 = 9600; 3 = 19200.	baud	0...3	3	3	3	2
LP	MODBUS parity bits. 0 = None; 1 = Odd; 2 = Even.	---	0...2	2	2	2	2
ENERGY SAVING Group							
HE2	Manual energy saving duration.	min	0...999	0	0	0	2
H01	Daily start time of energy saving temperature.	h	0...23	0	0	0	2
H02	Duration of daily energy saving.	h	0...24	0	0	0	2

10. DIAGNOSTICS

The table below lists alarms with their corresponding solutions. To signal an alarm, the LED alarm lights up  and the buzzer sounds. Every alarm is recorded in the Alarm menu.

10.1 TABLE OF ALARMS

Code	Description	Cause	Effects	Resolution
Pr1	Probe error	<ul style="list-style-type: none"> Probe not working Probe incorrectly connected Incorrect type of probe 	<ul style="list-style-type: none"> Code Pr1 displayed Compressor regulated according to C4 and C5 Heat regulation suspended 	<ul style="list-style-type: none"> Check the type of probe (PO) Check probe wiring Change type of probe
Pr2			<ul style="list-style-type: none"> Code Pr2 displayed Humid./dehumid. regulation suspended. Upon saturation, the regulator applies a time AH7 before generating the alarm 	
Pr3			<ul style="list-style-type: none"> Code Pr3 displayed If Pr3 = 5, end defrost is due to timeout. 	
AL	Low temperature alarm Pb1	Temperature Pb1 > A1 for a time equal to A7	<ul style="list-style-type: none"> Code AL displayed No effect on regulation 	Wait until the temperature read by Pb1 goes below the alarm threshold (A1-A11)
AH	High temperature alarm Pb1	Temperature Pb1 > A4 for a time equal to A7	<ul style="list-style-type: none"> Code AH displayed No effect on regulation 	Wait until the temperature read by Pb1 goes above the alarm threshold (A4+A11)
AL2	Low humidity Pb2 alarm	Humidity Pb2 > AH1 for a time equal to AH7	<ul style="list-style-type: none"> Code AL displayed No effect on regulation 	Wait until the temperature read by Pb2 goes below the alarm threshold (AH1-2%)
AH2	High humidity Pb2 alarm	Humidity Pb2 < AH4 for a time equal to AH7	<ul style="list-style-type: none"> Code AH2 displayed No effect on regulation 	Wait until the temperature read by Pb2 goes above the alarm threshold (AH4+2%)
id	Door open alarm	Digital input activated for a time > i2	<ul style="list-style-type: none"> Code id displayed Regulators blocked depending on the current function in iC1 = 7, 8 or 9 	<ul style="list-style-type: none"> If i2 = -1 the alarm is disabled; Check i2 and iP1
COH	Condenser overheat signal	Condenser temperature > C6	<ul style="list-style-type: none"> Code COH displayed No effect on regulation 	Check C6
CSd	High condensation alarm	Condenser temperature > C7 for a time equal to C8	<ul style="list-style-type: none"> Code CSd displayed Compressor locked 	<ul style="list-style-type: none"> Switch the device off then on again; Check C7 and C8
iA	Multi-purpose input alarm	Digital input activated (iC1 = 2) for a time equal to i5	<ul style="list-style-type: none"> Code iA displayed No effect on regulation 	Check i5
dFd	Defrost timeout alarm	Defrost terminated due to timeout and not to reaching temperature d2	<ul style="list-style-type: none"> Code dFd displayed Alarm icon  flashing No effect on regulation 	<ul style="list-style-type: none"> Touch any key Check d2, d3 and d11
HP	Digital pressure switch alarm	Pressure switch alarm activated due to digital pressure switch	<ul style="list-style-type: none"> Compressor and dehumidification blocked The regulator counts the number of events i8 in the time i6 from the first one 	Check and remove the cause of the digital input alarm (automatic reset with i6 = 0)
CtH	Thermal switch 1 alarm	Digital input activated (iC1 = 5)	The regulator counts the number of events i8 in the time i7 from the first one	If i7 = 0 alarm is always automatically reset
rtc	Clock alarm	Clock (RTC) alarm not working	Clock-connected functions not present or not synchronised with the actual time	Set the right time. If the error persists, replace the device (RTC battery dead)
PF	Power failure alarm	Power failure for a time > A10	Code PF is recorded	Check the power supply wiring

This document and the solutions contained therein are the intellectual property of EVCO and thus protected by the Italian Intellectual Property Rights Code (CPI). EVCO forbids the reproduction and distribution, even in part, of the contents, unless express authorisation is obtained directly from EVCO.

The customer (manufacturer, installer or end user) assumes all responsibility for the configuration of the device.

EVCO accepts no liability for any possible errors in this document and reserves the right to make any changes at any time without prejudice to the essential functional and safety features of the equipment.

MADE IN ITALY

EVCO S.p.A.

Via Feltre 81, 32036 Sedico (BL) ITALY

Telephone: +39 0437 8422

Fax: +39 0437 83648

Email: info@evco.it

Web: www.evco.it

