

HPN SERIES

HIGH PRESSURE PROPORTIONAL HUMIDIFIER

CENTRAL UNITS, SOLENOIDS CARDS AND DISTRIBUTION RACK

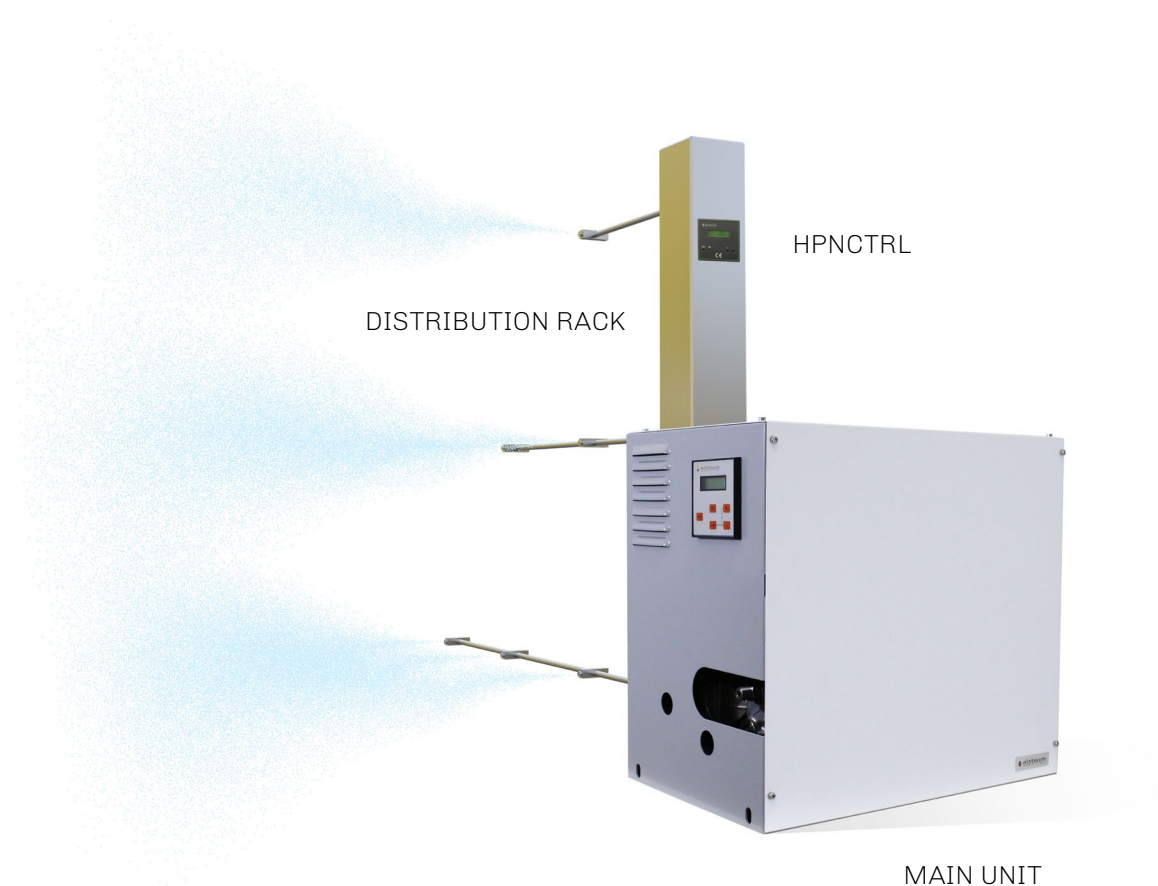

USER, INSTALLATION AND MAINTENANCE GUIDE

TOC

1	PACKAGE CONTENT	3
2	SAFETY MEASURES	3
2.1	GROUND CONNECTION.....	3
2.2	THERMO-HYGROMETRIC CONDITIONS OF THE INSTALLATION.....	3
2.3	ELECTRICAL CONNECTIONS.....	3
2.4	HYDRAULIC CONNECTIONS.....	3
2.5	WASTE DISPOSAL.....	4
2.6	WARRANTY.....	4
3	MANUFACTURER	4
4	WORKING PRINCIPLE	5
5	CHARACTERISTICS	6
6	INSTALLATION PRINCIPLES	7
7	INSTALLATION	8
7.1	MAIN UNIT.....	8
7.2	HPNCTRL.....	8
7.3	DISTRIBUTION RACK.....	8
7.4	DROPLET SEPARATOR.....	9
7.5	HYDRAULICS CONNECTIONS.....	9
7.6	ELECTRICAL CONNECTIONS.....	10
7.7	SETTING OF THE BYPASS CONTROL VALVE.....	11
8	MAINTENANCE	11
9	ELECTRONIC CONTROLLER	12
9.1	NORMAL OPERATION DISPLAY.....	12
9.2	ELECTRONIC CONTROLLER BASIC PROGRAMMING.....	12
9.3	ELECTRONIC CONTROLLER ADVANCED PROGRAMMING (ONLY FOR MAINTENANCE/FITTER).....	14
10	ALARM MESSAGES	16
11	CONNECTIONS DIAGRAM	17

Please before using your equipment read this guide carefully, by noting all the precautions and safety instructions reported in it. Keep your equipment in good operative conditions.

Familiarize with the working and security instructions related to the operation of your apparatus before trying to make it function. Keep this guide and any other booklet provided with your apparatus to be able to refer to them later.

1 Package content

The High Pressure Humidifier package is composed of:

- ◇ The high pressure humidifier central unit
- ◇ This user guide
- ◇ The high pressure pump user manual
- ◇ The inverter user manual
- ◇ A yellow cap for the pump oil to replace the red one (to be used only for transport)

2 Safety measures

People who are not familiar with this type of apparatus or which did not read attentively this guide do not have to be authorized to use the humidifier.

The humidifier is designed to be used on alternative 220Vac 50/60 Hz only. Do not try to connect it to a different type of supply. Check that the sector supply voltage corresponds to that of the apparatus.

The humidifier must always be switched-off before any maintenance operations.

All operations of maintenance and repairs must be carried out by the manufacturer, his technical service or any other qualified personnel to avoid any problem.

Do not cover any opening of the humidifier and do not insert objects in the openings

2.1 Ground Connection

The first operation of each installation is the correct ground connection for the equipment, following the safety regulations of the state and at the time when the equipment is installed.

2.2 Thermo-hygrometric conditions of the installation

Check that the environmental conditions of the place where the installation is carried out are always compatible with the requirements of the product as indicated in this manual. ELSTEAM products cannot be installed exposed to weather conditions or frost, unless different conditions explicitly expressed in countersigned documents.

2.3 Electrical Connections

ELSTEAM equipment must be connected to the power supply by carefully following the local regulations and the specifications on the plates of the equipment.

In particular, it is mandatory that the power supply lines have a correct section and are equipped with a standard disconnecting switch with differential safety (life-saving device) capable of protecting the user not only against the device, but also against the power lines installed.

2.4 Hydraulic Connections

ELSTEAM equipment needs to be connected to the water supply. Supply water shall comply with microbiological requirements of the German Drinking Water Ordinance (TrinkwV). Only ELSTEAM HPN DEMI humidifier complies with VDI6022 certification when using reverse osmosis water (not in contact with drinking-water mains). Should the unit be installed using normal water the installer must use a VDI 6022 non return valve to be still compliant.

It is necessary to strictly comply with the local active regulations (for installation) and make sure that any breakages or water leaks deriving from the installation or from the units itself cannot cause damage to the environment or to third parties. Do not install the equipment on passageways or over dangerous or susceptible objects and always provide special drainage systems that can evacuate any spilled water

correctly.

2.5 Waste Disposal



Directive 2002/96 / EC of the European Parliament and the related national regulations impose the obligation not to dispose of WEEE as urban civil waste, but to prepare a special collection for outdated parts of the humidifier.

The purchaser has the right to return the disused humidifier to ELSTEAM srl in case of purchase of an equivalent humidifier. ELSTEAM will arrange for its own disposal or through its appointees.

The disposal of electrical or electronic components in an abusive manner and not in compliance with current regulations involves penalties.

2.6 Warranty

ELSTEAM Srl recognizes on its products the legal guarantees in force at the time of sale of the product. Incorrect use and lack of maintenance entail the automatic forfeiture of any form of guarantee.

3 Manufacturer

Manufacturer

ELSTEAM S.r.l.
Via ENRICO FERMI 496, 21042 CARONNO PERTUSELLA (VA) - ITALY

Contact

Tel.: (0039) 029659890
Fax: (0039) 0296457007
Email: info@elsteam.it
Web: www.elsteam.com

4 Working principle

The high-pressure humidifier performs an adiabatic humidification by atomization of softened water or standard water at high pressure.

The system is composed by a central unit, a network control unit (HPNCTRL), a distribution rack and the droplet separator (at the end of the humidification section, only for AHU installation).

The central unit maintains the pressure in the distribution network at a constant value (established based on the model of nozzles used) as the number of active network sections varies.

The HPNCTRL, for proportional control of the distribution network, is installed in the environment to be humidified or inside the AHU, managing section solenoids to make proportional production and feed/drain solenoids to activate/empty the distribution network. One HPNCTRL must be installed for each zone to control. The HPNCTRL card receive proportional or ON/OFF signal from the controlling system and provide signals to the distribution networks solenoids and to the central unit. The HPNCTRL unit opens the drain solenoid to empty the distribution rack when the control signal is 0.

The droplet eliminator is used to stop the droplets of water that are not completely evaporated before they enter in the duct.

6 Installation Principles

The figure below shows the basic working principle of the proportional humidifier. The output signal of

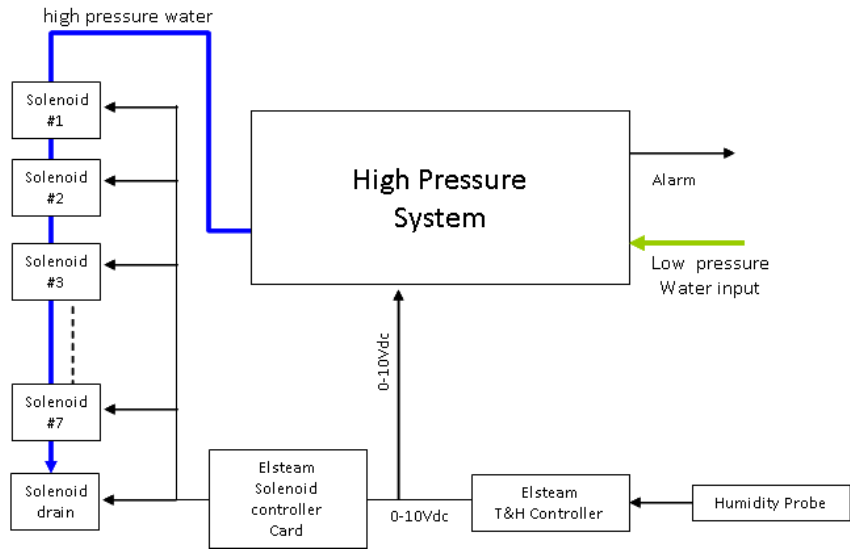

the humidistat (0-10V) controls the solenoids controlled card (for proportional working mode) as well as the activation (threshold set at 1V) of the high pressure system.

The following figure shows instead an implementation of an installation with the network of nozzles split in three sections with 33% and 66% thresholds.

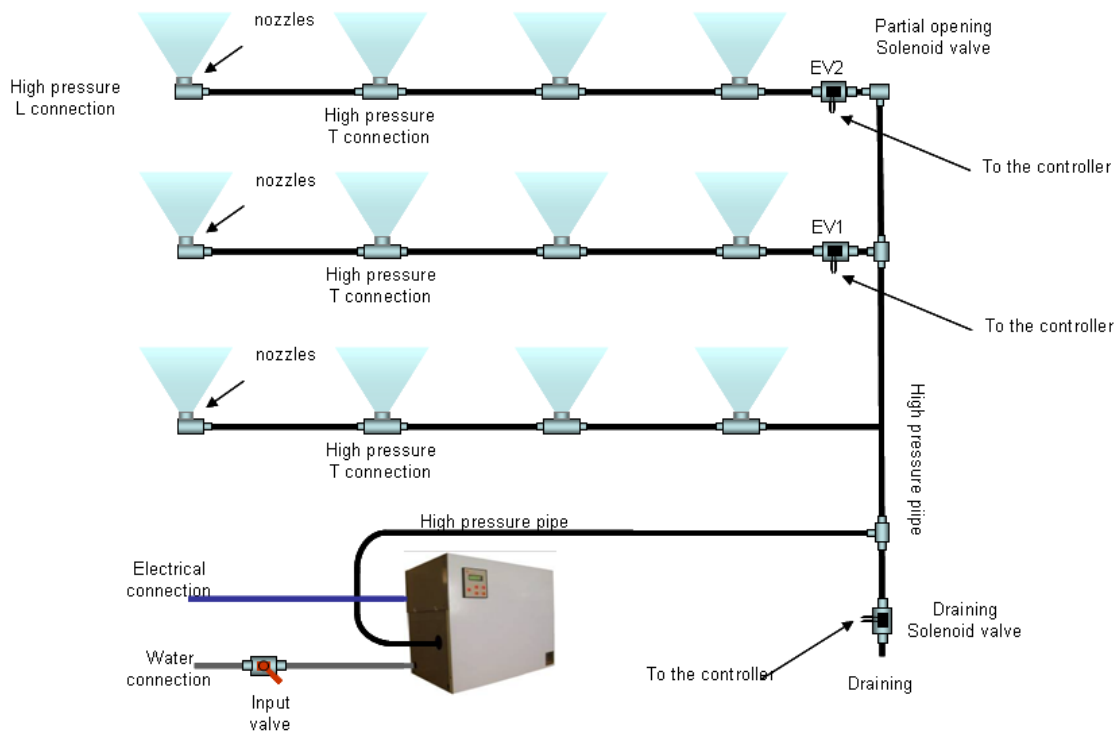

7 Installation

7.1 Main unit

The cabinet of the humidification system must be installed in a ventilated and protected place. It must be placed on a flat and stable surface. For a correct use and operation, as well as for an easy maintenance, leave enough free space around the machine. To enable the correct ventilation of the unit is necessary to ensure a free space of at least 20 cm close to the perforated panel for ventilation, which is located on the right wall of the machine.

Do not place the machine in dangerous and/or explosive/inflammable places.

After installation the red cap of the oil tank, used for the transport, must be replaced by the yellow one, used for normal working operation, provided with the system.

The access internal parts of the cabinet remove screws that secure the top and side panels.



During the first installation and all the operations of maintenance please take care of the temperature sensor installed at the exit of high pressure pump. Its damage may cause the breakage of the high pressure system.



Before first switch-On replace the RED transport cap with the YELLOW cap having a built-in dipstick provided.

7.2 HPNCTRL

The HPNCTRL card must be installed close to the distribution rack.

Electrical connections scheme is reported at the end of the document. Electrical connections to the high-pressure solenoids (section, feed and drain) and main unit must be realised respecting local regulation.

The HPNCRTL card receives the regulation signal (ON/OFF or Proportional).

The HPNCRTL unit opens the drain solenoid to empty the solenoids lines when the control signal is 0.



The control signal must be 0 in case of ventilation system failure or system shut off

7.3 Distribution rack

The case of the rack must be installed external to the AHU and fixed using dedicated holes. Hydraulic connections to the rack (high pressure water input and drain) are respectively on the top and bottom of the case. Three holes must be realised into the sandwich panel to let nozzle lines enter the AHU. When mounting the nozzle lines a slope towards the case must be realised. This slope allows the lines to empty totally when the system is off.

The rack must be installed in direct contact (thermally connected) to the HEATING COIL, to let the rack dry when it is not used.

When shutting down the system for long periods, the humidifier must be switched-off before the ventilation system, so to assure that the humidifier chamber is dry before complete shutdown.

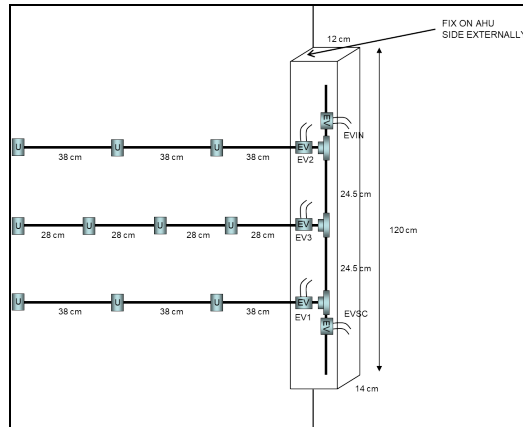

The nozzle lines must be connected in thermal contact with heating batteries in AHU, to be sure the stainless steel pipes are always at drying temperature when the humidifier is not working. This will dry the empty network avoiding all possibilities of microbes growth and proliferation.



When installing the distribution rack (inside the AHU) the holes opened in the panel of the must be closed using permanent elastic sealant that fulfils the requirement of the standard VDI 6022-1.

7.4 Droplet separator

The "droplet separator" is made of stainless steel frame and glass fiber panel. It must be installed (only in AHU) at minimum 150cm from the distribution network. It is care of the AHU manufacturer to make stainless steel frame avoiding sharp edges and all corner than can allow dust deposits. Permanent elastic sealant must be used in such a way to avoid dirt accumulation (make surfaces as smooth as possible). The droplet separator must be easily removable to perform maintenance operation or unit replacing. As the droplet eliminator is not intended to be cleaned, it must be replaced at end of its lifetime.



When installing the droplet separator (inside the AHU) the holes opened in the panel of the must be closed using permanent elastic sealant that fulfils the requirement of the standard VDI 6022-1.

7.5 Hydraulics connections

The connection between the pump and distribution network must be realized using pipes which supports nominal pressure of 100bar (minimum), due to the high pressure (80 bar) in the network. It is preferable to use stainless steel material.

Hydraulic connections are positioned on side panels of the cabinet. Input water connection is 3/4" and is on the right side of the case; output is 3/8" and is on the left side.



A shut-off valve must be installed upstream (and nearby) humidifier for maintenance and safety reasons operations.



*Before installing the nozzles, it is mandatory to carry out a cleaning phase of the pipes installed to **remove** all deposits in the pipes.*



Only HPNxxDEMI models complies with VDI6022 standards.

The High Pressure Humidifier can work with standard or demineralised water. Different pumps materials (STAINLESS STEEL for reverse osmosis water, BRASS for normal tap water) are used in the two versions. The water pressure at the input must not be lower than 1bar.

For proper operation in according to VDI standards, stagnation of water in supply lines shall be avoided. When shutting down the system for long periods particular care must be taken to empty supply lines or keep active water treatment systems.

7.6 Electrical Connections



Prior to carrying out any inspection or service on the machine, it is necessary to disconnect it from the main electrical supply. Make sure, that nobody can reconnect it during the technical service.
Every installed electrical and electronic equipment or basic structure must be earthed.



All operations of electrical installation MUST be performed by qualified personnel (eg electrician or staff with appropriate training) only.
The customer is responsible for the use of qualified personnel.

Before starting installation:

- ◇ Check that the supply voltage and the frequency correspond to those indicated on the rating plate.
- ◇ The dimensions of the supply cable must suit the machine absorption and comply with the current regulations.
- ◇ Put the cable in the relevant cable passage hole and then tighten.

Connectors for electrical connections are located inside the upper part of the cabinet (to access it you need to remove the upper panel of the cabinet). It is recommended to isolate the machine from the mains before each intervention and in any case in absence of protective covers (dangerously live electrical parts are present inside).

The power supply line must be connected to the input of the circuit breaker, for the ground connection there is a special yellow-green terminal, the hole for the cables is located on the rear of the cabinet.

Controls and alarm signals are found in the card connectors (to access it, remove the upper panel of the cabinet) and the opening for these cables is also in the rear of the cabinet.

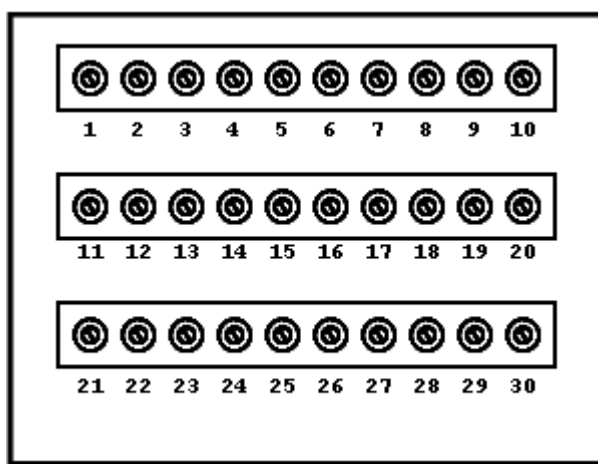

Controller Terminal Block

N°	Name	Description
3	ALARM	Alarm Normally opened contact. (Max. 2A, 230V).
4	ALARM	
5	REQ	NOT USED
6	REQ	
7	0 V	Ground reference voltage (0V)
8	REG	Input Control Signal (0-10V)
9	V+	Positive Reference Voltage (12V)
10	RTH	NOT USED
11	ACOUT	NOT USED

All connections between the controller and the solenoid card are made at the factory. The user must connect the output signal of the humidistat to the terminals 7 (-) and 8 (+) taking care of polarities. For ON/OFF driving connect the wires to terminals 8 and 9.

The HPNCTRL card proportional or ON/OFF control signal must be shut off in case of ventilation failure or AHU shutdown to stop mist entering into the AHU without airflow.

7.7 Setting of the bypass control valve

The high-pressure system has a bypass valve for regulating the output pressure. At first power on is necessary to control the adjustment of this valve.

In the case of a successful installation, you can adjust the maximum pressure (turning clockwise the valve). **It is advisable to adjust the output pressure up to a pressure of about 80 bar.**

It's also possible to reduce the output pressure in case "Etb" message is displayed on the inverter display (lower limit for output pressure is 30bar).

8 Maintenance

A high pressure humidification system requires some periodic maintenance operations for its proper operation:

- Change the oil pump every 500 hours, as indicated on the attached manual pump, closing the inlet water and removing the top caps and bottom as shown in figure

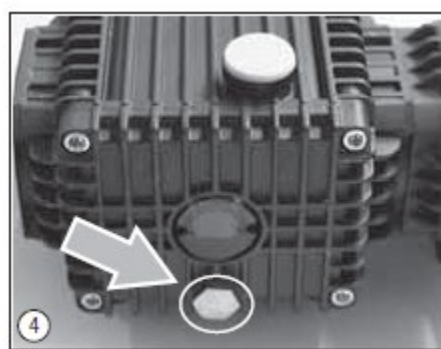
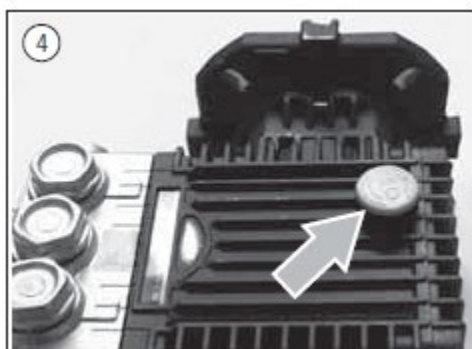

- Periodically check the wear of the nozzles. The nozzles worn may cause the blocking of the machine due to an excessive reduction of output pressure
- Check periodically pump oil level:

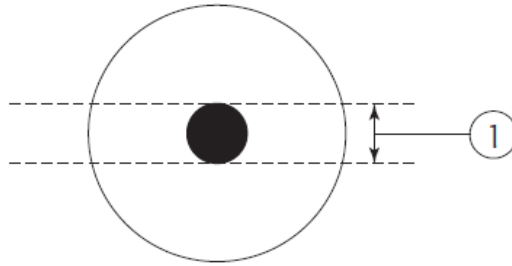

If oil level is not within ① zone, add or remove oil in the tank. Check for oil leaks.

NOTE

The high pressure humidifier presents a thermal protection for the pump system. Be extremely careful not to damage the temperature sensor mounted on the pump.

9 Electronic Controller

All operation of the high pressure humidifier are managed by a micro controller based board. All information is provided through a 16 characters by 2 lines display. Its main functions are:

- Switch On/Off of the system
- Check the real working time of the system
- Provide information about replacement of spare parts and pump oil.
- Display information about parameters
- Provide different alarms

9.1 Normal operation DISPLAY

H	P	N			①		T	②				③		W	i
P	o	u	t	=	x	x	.	x				b	a	r	

During normal operation the electronic controller display show on the first line main parameters of the system:

① : System State:

- "u" : indicates proper operation of the system
- "!" : indicates temperature protection intervention
- "x" : indicates that no request is present

② : Pump temperature indication bar

③ : Minimum operating time of the pump. At startup/shutdown of the pump "t" character is displayed. During the inhibit time (factory setting: 60 s). During this period system shutdown or startup is inhibited.

"W" character indicates that input water solenoid is opened

"i" character indicates that input water flow is sufficient for system operation. If "i" is not shown, there is a problem in input water flow or pressure.

The second line indicates the pressure value in the nozzles network.

9.2 Electronic controller basic programming



During the first programming of the controller is advisable to disconnect the control signals (Pin 8 of the terminal) to avoid that the humidifier is put into operation.

To enter the basic programming mode press the **SET** button for 2 seconds, until the following message is displayed:

Humidify System
-- Enabled --

To modify the value of a field or to move between fields use and buttons. During value changing, the value of the field blinks.

To end the programming of a field press the button to set the new value, button to cancel modification or , or for more than 3 seconds to exit programming phase.

Programming phase automatically ends without current parameter update if no button is pressed for 3 seconds.

Note: To save updated values do not abandon programming pressing button.

Basic menu programming fields are:

Display	Description
Humidify System	Enable or disable the humidifier "Enabled", System on "Disabled", System off
Life Time	Display the effective working time of the system This field is read only. Cannot be modified by the user
Change Oil Timer	Display the remaining time before pump oil change c. Cannot be modified by the user

9.2.1 Counter of the remaining time before pump oil change

The high pressure pump requires changing the oil every 500 hours of operation (the first oil change should be made after 50 hours of operation). Use SAE 15W40 mineral oil. The quantity of oil needed depends on the pump flow. Please refer to the pump system manual for details.

The controller counts the time remaining for the next oil change. At the end of that period the message "ChangeOil xxxxxh" is displayed to inform user that oil must be changed. After this message there is still a period of 50 hours before the controller BLOCKS the system.

If oil is changed before scheduled time (before the controller blocks the system), the oil counter must be reset by pressing **SET** and **OK** buttons. When the message "Pump Oil has been changed" is displayed, press **OK** button to confirm and reset the counter. By pressing **CANC** button the counter is not reset and the system will stop at counter expiration.

At expiration of extended period the system will stop working and following message will be displayed "System Failure - Change the Oil of the Pump".

Once the oil is changed do not forget to reset the oil counter by pressing **OK** button. When the message "Pump Oil has been changed" is displayed, press **OK** button to confirm and reset the counter. By pressing **CANC** button the counter is not reset and the system will remain blocked.

9.2.2 Display of the remaining time

During normal working operation the user can display remaining time before oil change pressing **-** button.

9.2.3 LCD Contrast change

If necessary the user can modify the value of the display contrast pressing **CANC** button and one of **+** or **-** button.

9.2.4 Display of Firmware version

User can display the installed firmware version pressing **+** and **-** buttons.

9.3 Electronic controller advanced programming (only for maintenance/fitter)

Advanced programming mode allows maintenance people and fitters to modify additional parameters depending on the working conditions of the HPN system.

To enter the advanced programming mode press **SET** and **+** buttons for 2 seconds, until the following message is displayed:

Humidify System -- Enabled --

Advanced menu programming fields are:

Display	Description
Humidify System	Enable or disable the humidifier "Enabled", System on "Disabled", System off
Life Time	Display the effective working time of the system This field is read only. Cannot be modified by the user
Change Oil Timer	Display the remaining time before pump oil change This field is read only. Cannot be modified by the user
Pump Rate	Set the system flow rate Indicates the nozzle system flow rate, not the pump one. In the current version must be set to minimum value. Will be used to provide information about real water consumption.
Minimum External Signal xxx/100%	Minimum value of external controller signal (only proportional controller) This value is expressed in percentage of 10V. In case of noise on the external signal line, parameter value can be increased. (Default value 10%)
Output Pressure Timeout= xxx sec	Max time to reach standard pressure in the nozzles network If within this period from system start, pressure in the nozzles pipe has not reached the default value, the embedded controller stops the system providing the following error message "Low Output Pressure". To restart the system after failure solution, press OK . (Default value 60 sec)
Minimum On/Off Time = 000 sec	Minimum System On/Off time To avoid frequent stop and start of the pump (that can damage it) a minimum period is set by electronic controller. During this period switch on and off of the system is inhibited unless the circuit breaker is used (NOT RECOMMENDED). In cases of frequent starting and stopping of the pump, increase the value. (Default Value : 60 sec)
Std Pressure xxx bar	Standard value of pressure This parameter allows the fitter to modify the default value of the pressure in the nozzles network. (Default Value: 80bar)
4..20mA Coeff. P P= xx.xbar)yyyyy	Pressure transducer Coefficient On the second line of the LCD display the pressure value and probe coefficient are showed. (Default Value: 8850)



To confirm the changes made to a field, use **SET or **OK**. To exit the advanced programming mode, press **SET** or **OK**. To store the changes in the FLASH memory of the microcontroller press **SET** or **OK** for more than 3 seconds. Using the **CANC** key changes to a field will not be stored in FLASH and new values will be valid until the next switch off the humidifier (using circuit breaker).**

10 Alarm Messages

Message	Insufficient Water
Cause	Lack of input water Inverter security error
Possible Solution	Check input water flow. Check inverter display for error messages. If “Etб” message is displayed the output pressure security pressure switch stopped the system. Check the output bypass valve. Turn it counterclockwise to reduce output pressure. Remove one nozzle from the network and try the system. Press OK key to remove alarm condition and restart the system. If the alarm condition stops: <ul style="list-style-type: none"> • Replace nozzle and restart the system If the system is still in alarm, please contact ELSTEAM or your distributor for input flow meter replacement part.

Message	Check Load Valve Driver
Cause	Driving of input water solenoid failure
Possible Solution	If “W” character is displayed in the first line, check solenoid connections and voltage (12V). Press OK key to remove alarm condition and restart the system. If the system is still in alarm, please contact ELSTEAM or your distributor for part replacement.

Message	NTC failure
Cause	The pump temperature probe is damaged.
Possible Solution	Contact ELSTEAM or your distributor for part replacement.

Message	Low Output Pressure
Cause	The pressure in the nozzle pipe cannot reach the default value within the set period.
Possible Solution	Check distribution network and output connection pipe for draining. Check the output bypass valve. To increase the output pressure turn clockwise the valve.

Message	Pump Overheating, check atomizers
Cause	Pump temperature high.
Possible Solution	Check the output bypass valve. Turn it counterclockwise to reduce output pressure.

To remove alarm condition and restart the system press **OK** key.



CAUTION

*The controller stores the status of the humidifier in a FLASH memory.
Turning the system off and on to remove alarm conditions has no effect*

Connections Diagram

Connection diagram – single zone, proportional humidistat

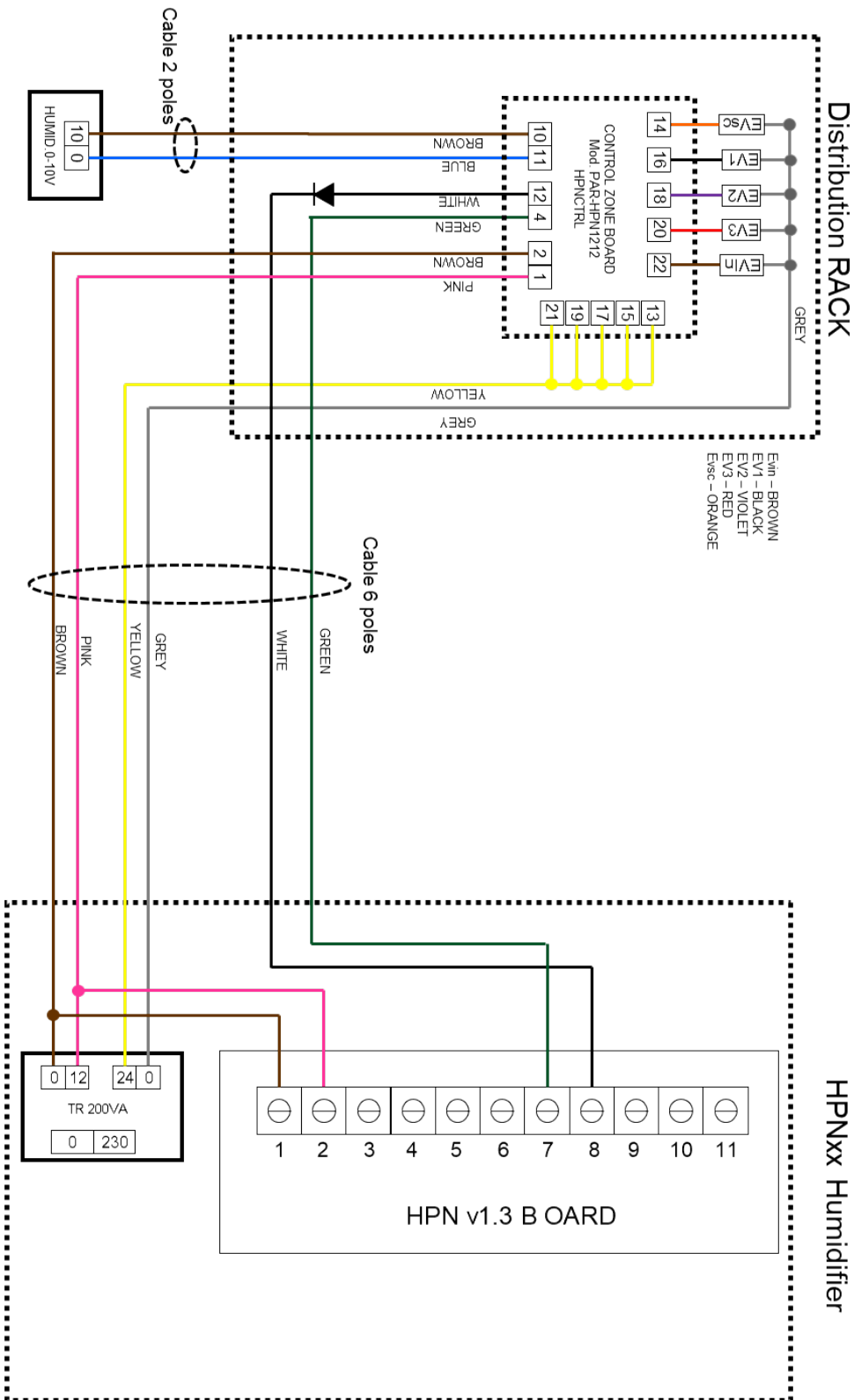

Rel. 20200304